

G 1

1200 - 3600 r/min

Ø125

3~ 400 V

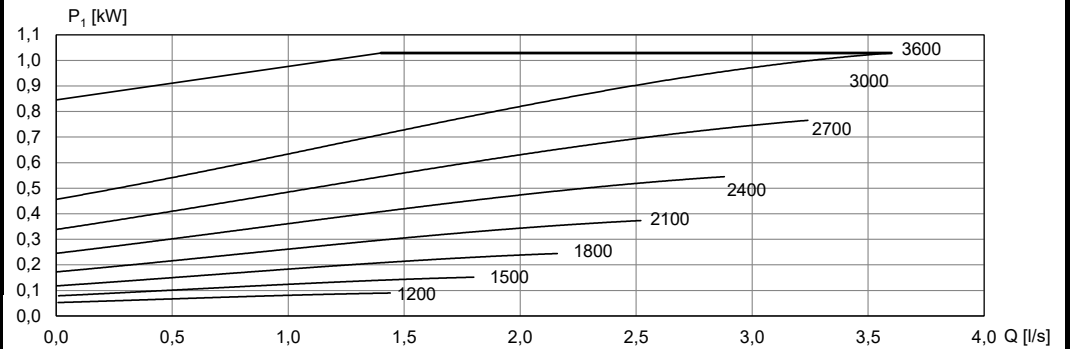
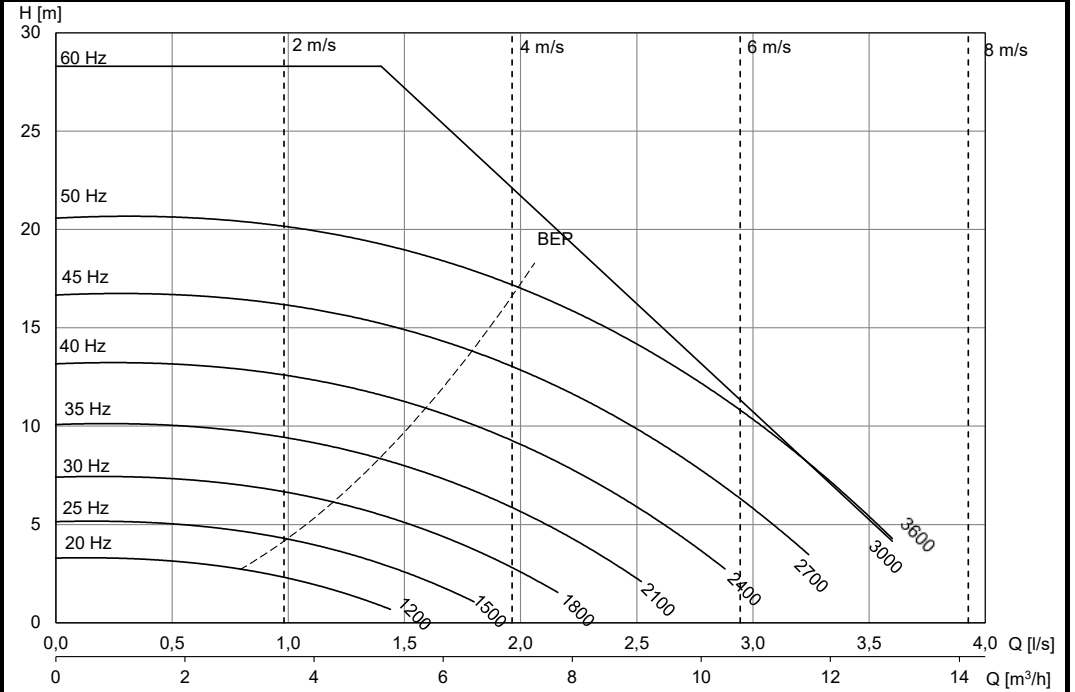
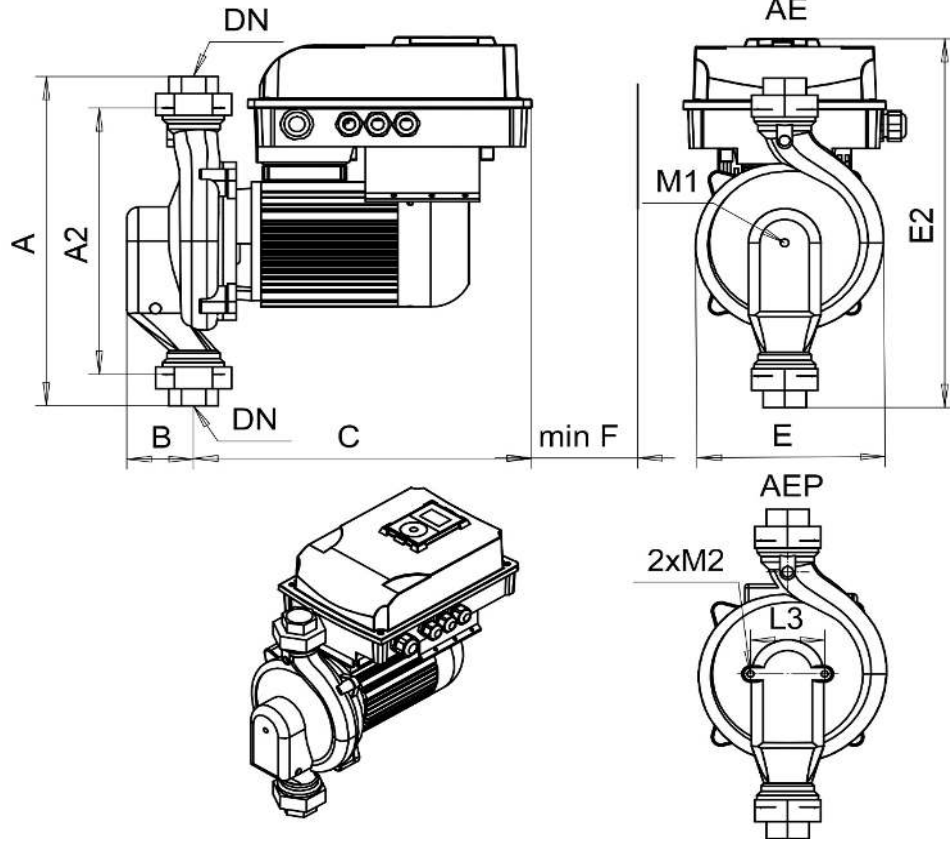

[mm]								
A	A2	B	C	minF	E	E2	L3	
318	260	53	365	150	170	400	55	
Motor				$P_{2N}$ [kW]	$I_N$ [A] (3x400V)	[kg]		
KPV5-80-1 N12				0,65	3,0	23		