

DN65

1200 - 3600 r/min

Ø158

3~ 400 V

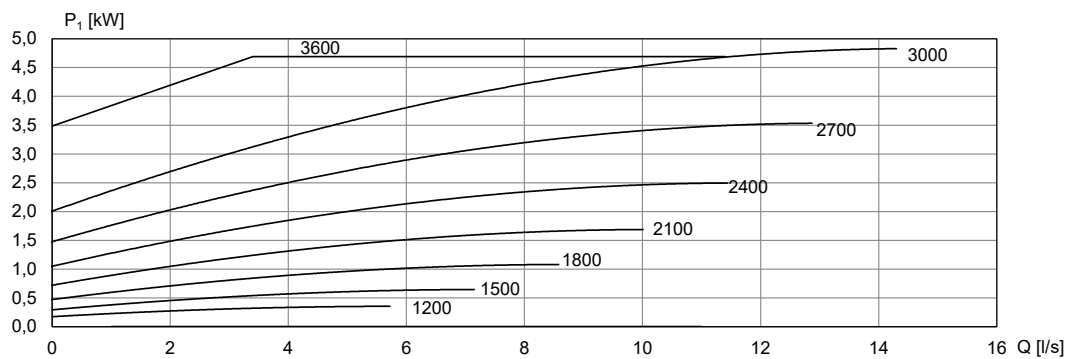
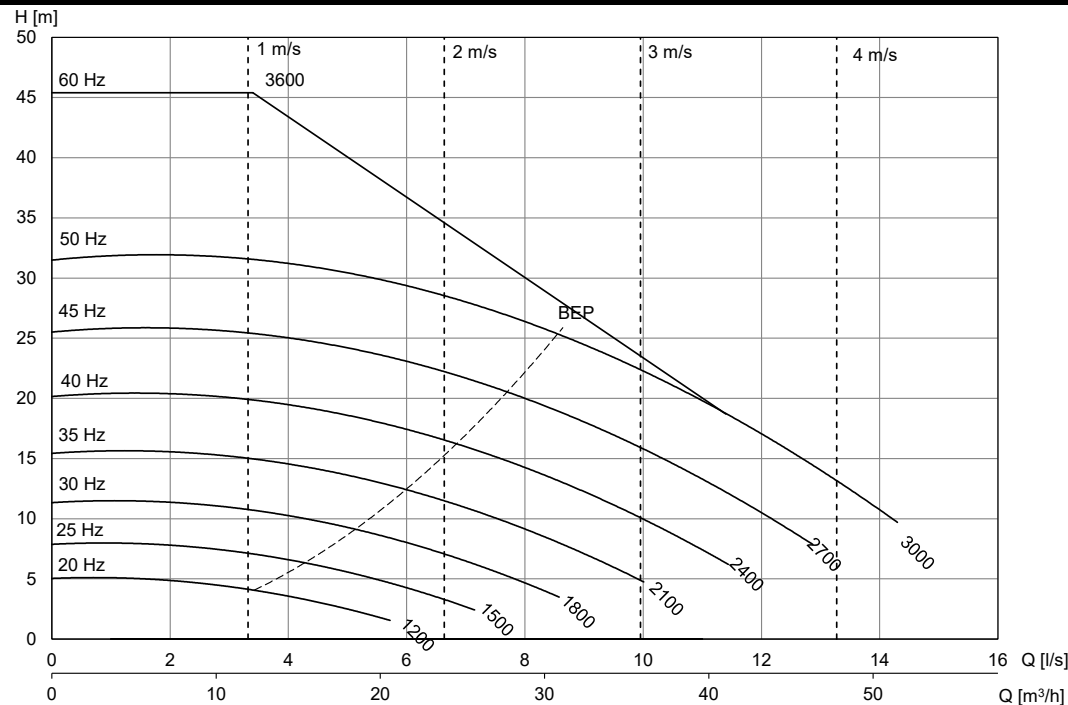
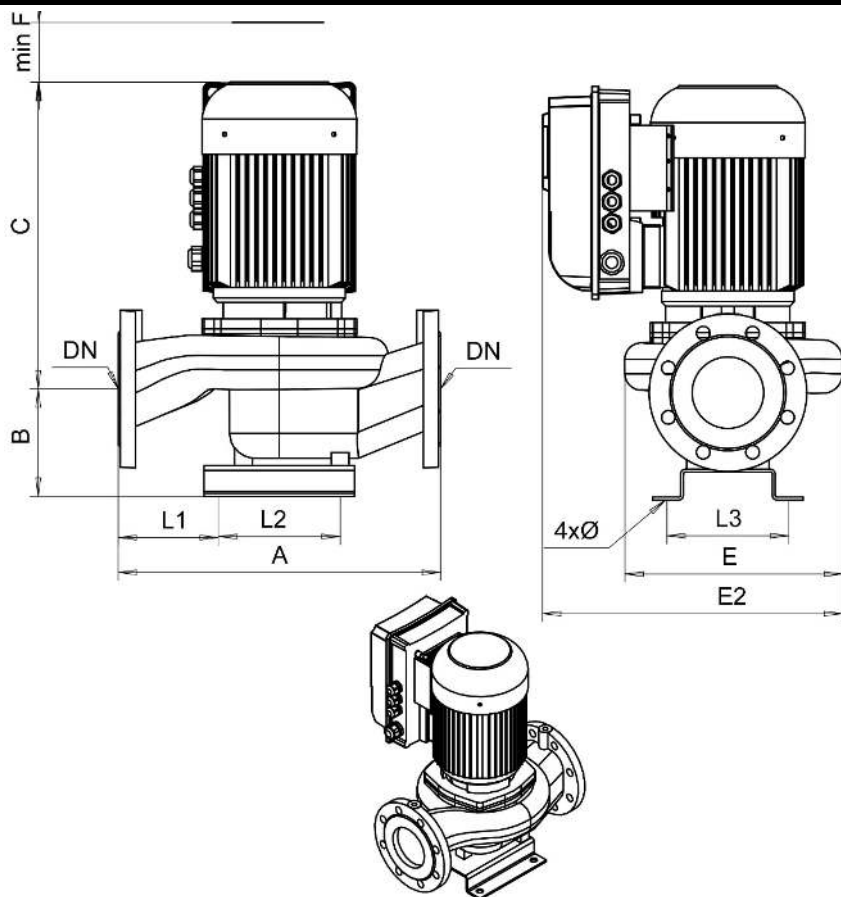

[mm]									
A	B	C	minF	E	E2	L1	L2	L3	Ø
360	125	460	150	255	410	93	170	170	16

Motor	P <sub>2N</sub> [kW]	I <sub>N</sub> [A] (3x400V)	[kg]
KPVS-112-1 F19	4	11,5	73