

DN100

600 - 1650 r/min

Ø172

3~ 400 V

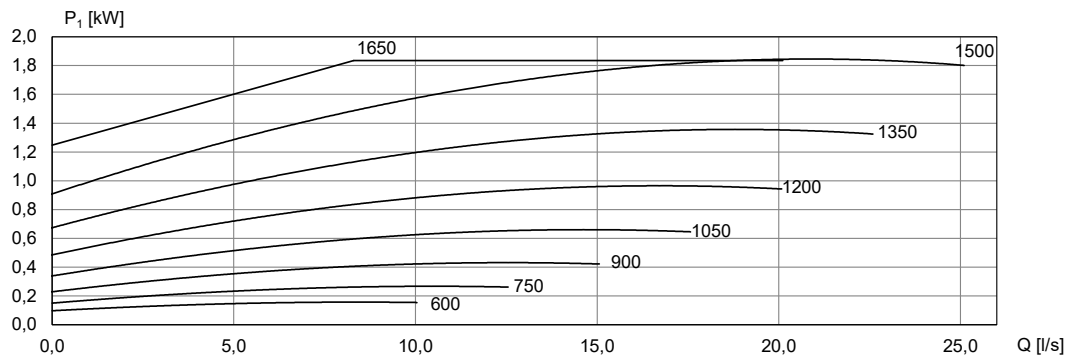
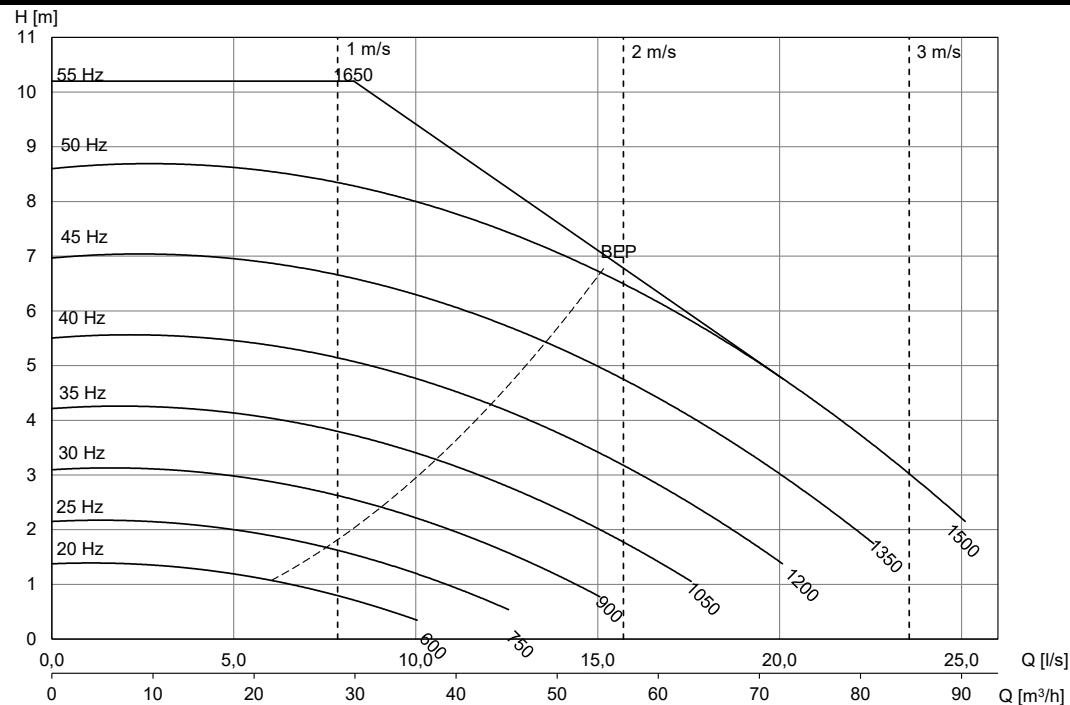
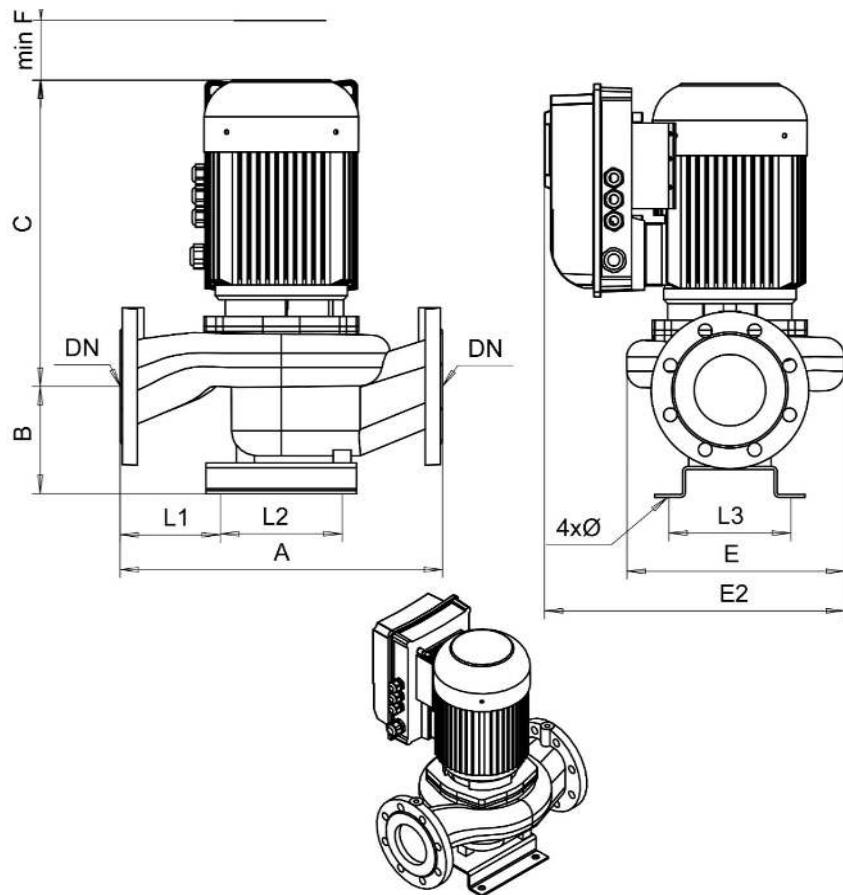

[mm]									
A	B	C	minF	E	E2	L1	L2	L3	Ø
450	150	465	150	300	415	140	170	170	16

Motor	P <sub>2N</sub> [kW]	I <sub>N</sub> [A] (3x400V)	[kg]
KPVS-90-2 F19	1,5	4,0	66