

L-65B/2 VS

LH-65B/2 VS

LS-65B/2 VS

DN65

1200 - 3600 r/min

Ø174

3~ 400 V

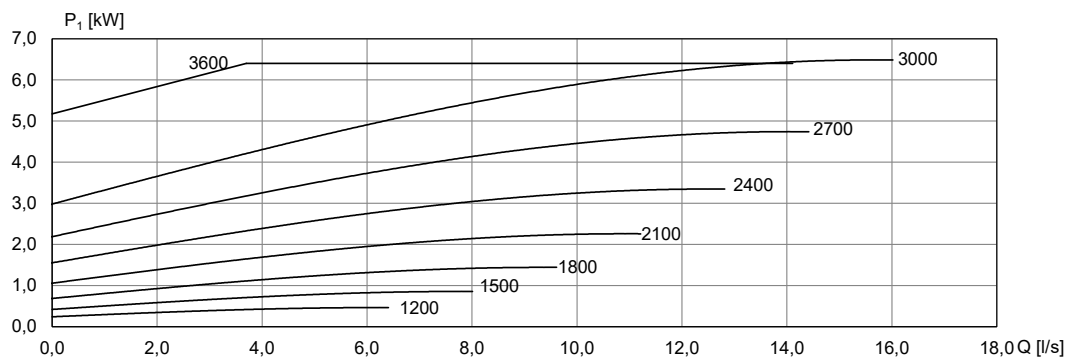
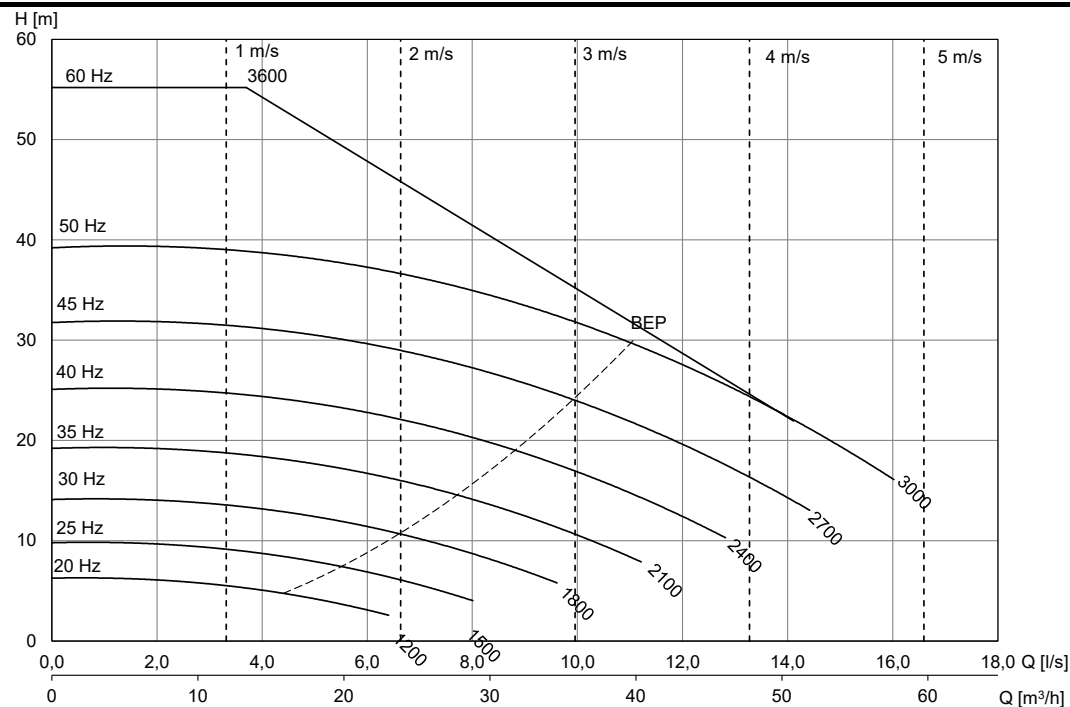
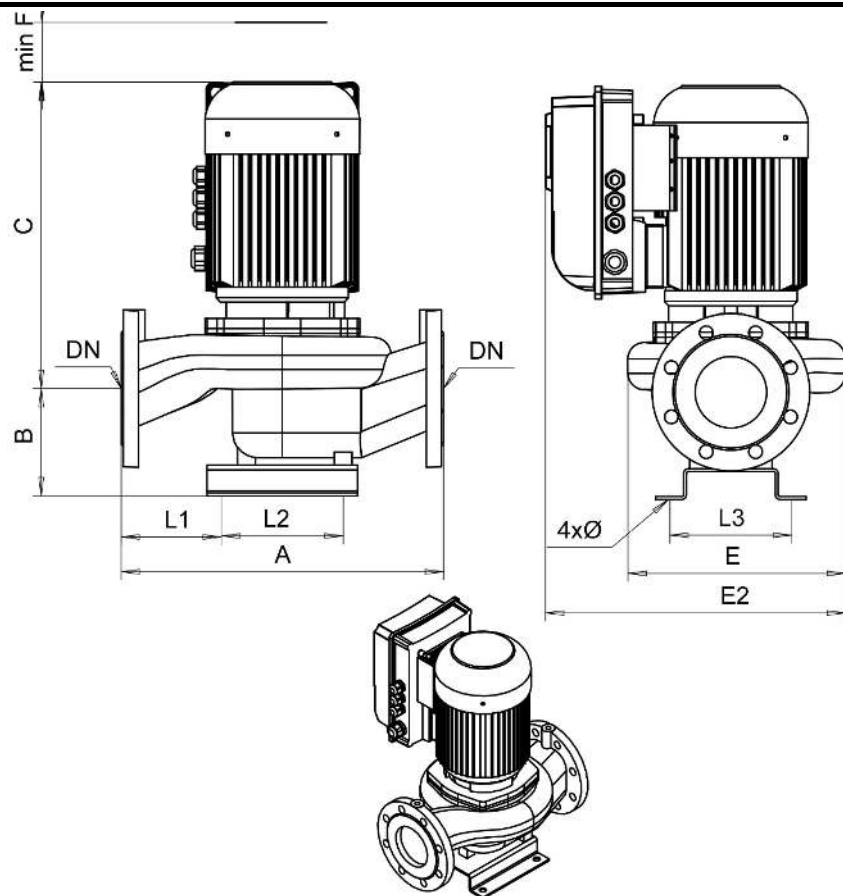

[mm]									
A	B	C	minF	E	E2	L1	L2	L3	Ø
340	125	540	150	255	465	83	170	170	16

Motor	P_{2N} [kW]	I_N [A] (3x400V)	[kg]
KPVS-132 E1 F19	5,5	14,2	103