

ALS-1081/2

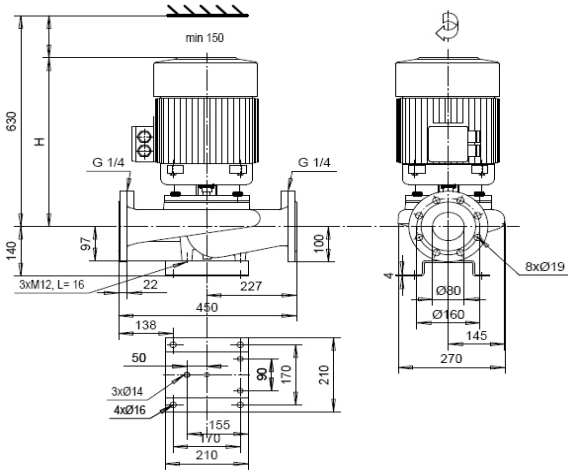

Motor 400V	P_{2N} [kW]	I_N [A]	I_{max} [A]	[kg]	H [mm]	
	ZH05	KP-90-1 F19	2,2	4,29	5,1	53
KP-100-1 F19	3	5,69	6,7	59	480	
KP-112-1 F19	4	7,53	8,5	73	470	
KP-132 E1 F19	5,5	10,22	14,7	92	480	
KP-132 E1 F19	7,5	13,27	14,7	99	480	
Motor 380-400V(460-480V)	P_{2N} [kW]	I_N [A]	I_{max} [A]	[kg]	H [mm]	
ZH09	KP-100-1 F19	3 (3,6)	5,85 (6,00)	5,1	59	480
KP-112-1 F19	4 (4,8)	7,80 (8,01)	6,7	73	470	
KP-132 E1 F19	5,5 (6,6)	10,38 (10,80)	8,5	92	480	
KP-132 E1 F19	7,5 (9)	13,19 (13,91)	14,7	99	480	

