

LP-50A/4 VS

DN50

600 - 1800 r/min

Ø150

3~ 400 V

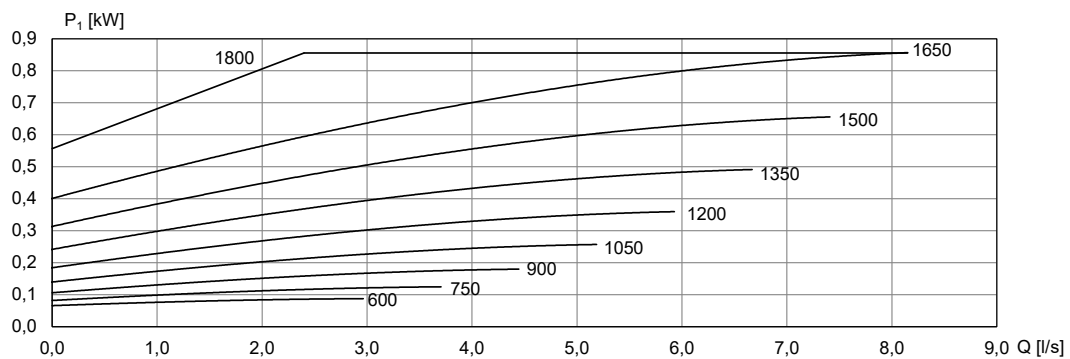
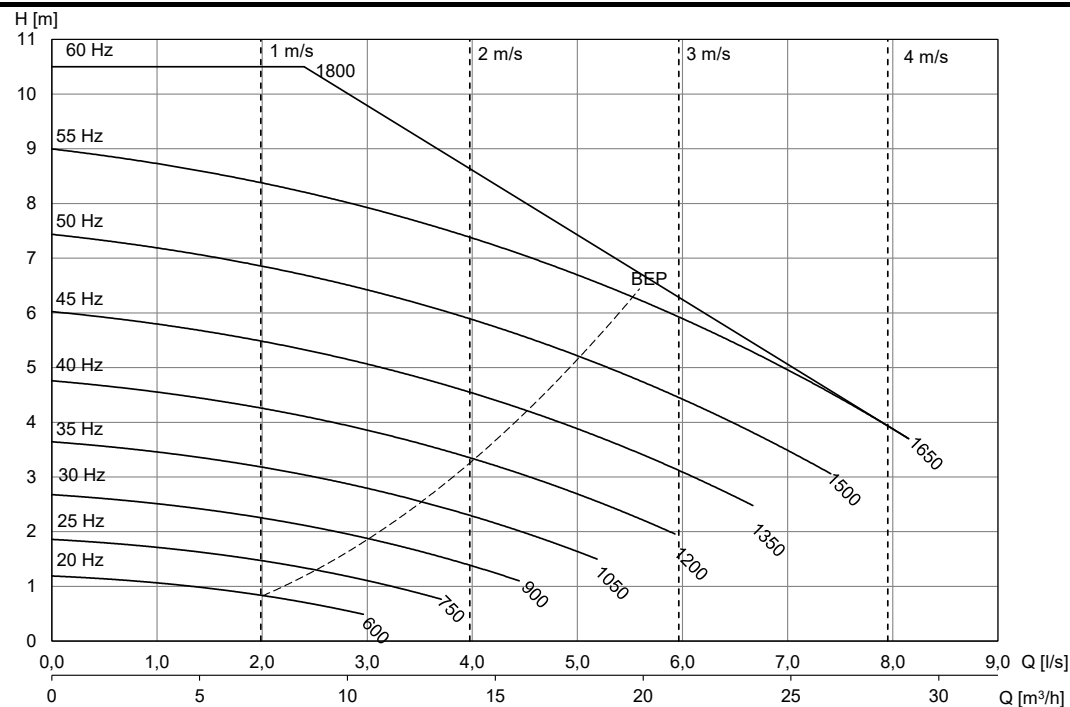
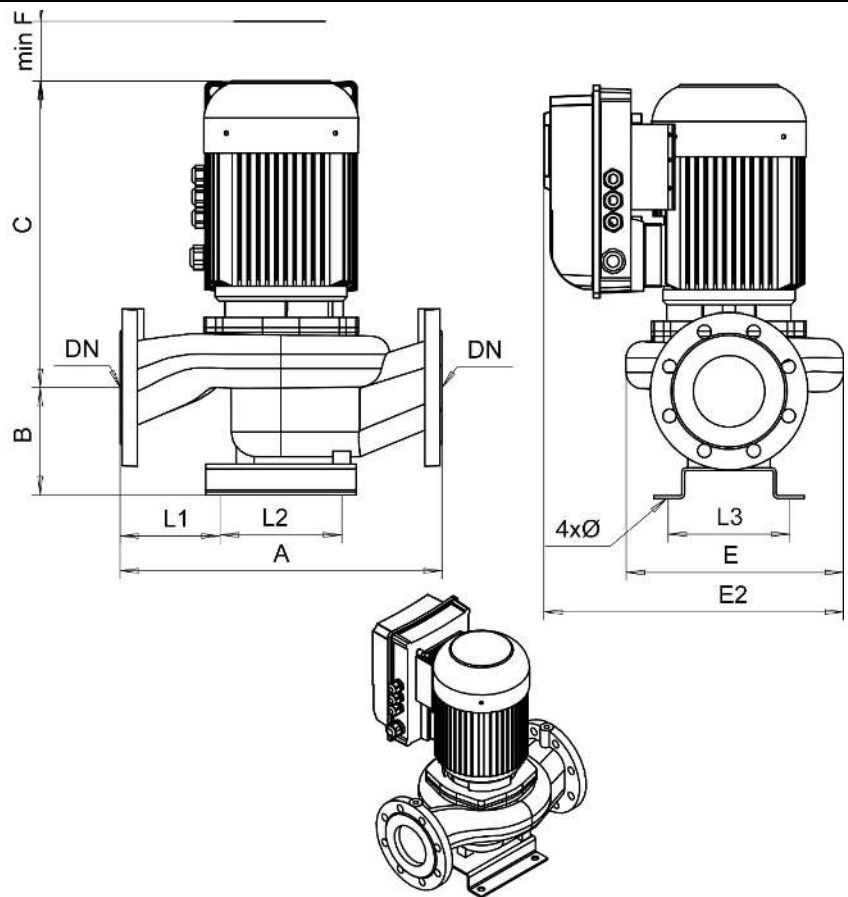

[mm]									
A	B	C	minF	E	E2	L1	L2	L3	Ø
280	93	405	150	205	355	55	170	170	16

Motor	P_{2N} [kW]	I_N [A] (3x400V)	[kg]
KPVS-80-2 F15	0,55	2,2	36