

# T-50A/4

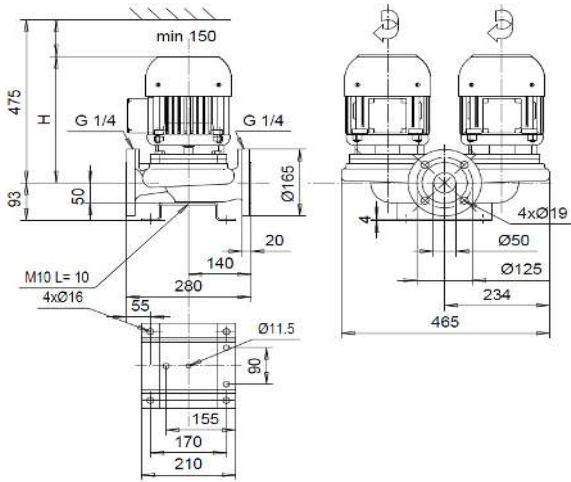

50 Hz	Motor 400V	$P_{2N}$ [kW]	$I_N$ [A]	$I_{max}$ [A]	[kg]	H [mm]
		OP-752 F15	0,20	0,57	0,7	46
	OP-772 F15	0,25	0,95	1,2	54	250
	OP-772 F15	0,37	1,11	1,2	54	265
	KP-80-2 F15	0,55	1,38	2,1	68	385

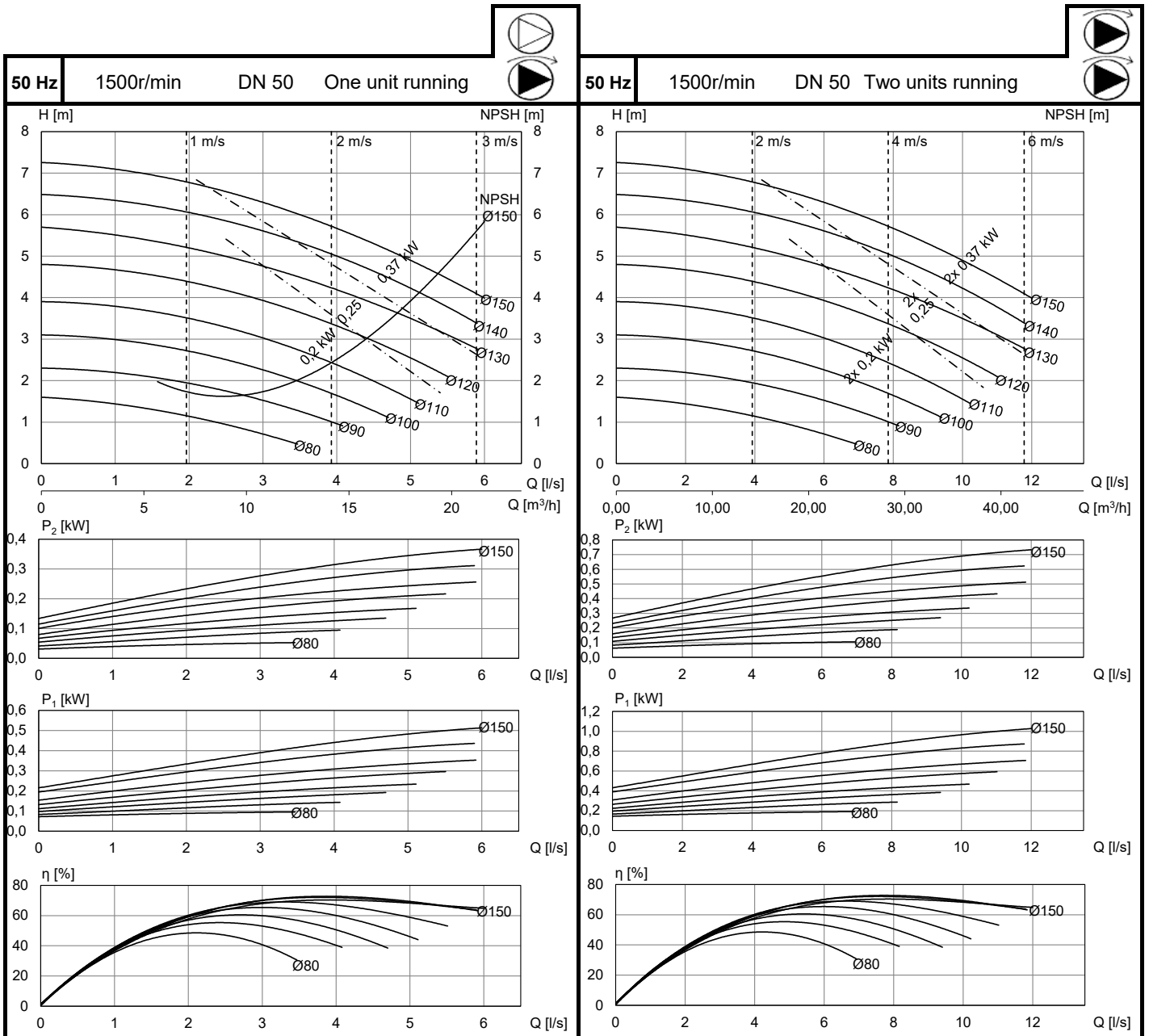

# T-50A/4

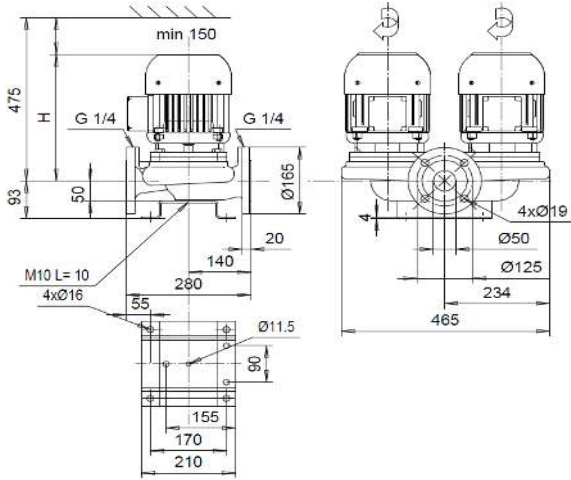

ZH09	Motor 380-400V(460-480V)	$P_{2N}$ [kW]	$I_N$ [A]	$I_{max}$ [A]	[kg]	H [mm]
	OP-752 F15	0,2 (0,24)	0,57 (0,60)	0,7	46	250
	OP-772 F15	0,25 (0,3)	0,95 (0,94)	1,2	54	265
	OP-772 F15	0,37 (0,44)	1,11 (1,10)	1,2	54	265
	KP-80-2 F15	0,55 (0,66)	1,42 (1,45)	2,1	68	385

