



Installation, Operation and Maintenance instructions

AE_, AKN_, AL_, AP, AT, KI, K_, L_, T

Inline centrifugal pumps



1 GENERAL

This product has safe and reliable operation in the function for which it is specified. A pump is a piece of equipment that has pressurized parts and rotating parts which can be dangerous. Thus, fully follow all the safety measures in the instructions. Personal injuries are possible if you do not follow the instructions.

The main heading Safety Instructions includes general health and safety instructions and also other safety information related to this supply. Such information includes all important requirements of national legislation and other safety information given by the plant operator.

The correct process and application data is important for the safe and reliable operation of the product. Environmental circumstances must be specified to Kolmeks before the pump delivery.

Such conditions are for example:

- Unusual temperature
- High humidity
- Atmospheres that cause corrosion
- Pressure changes in the process
- Flow below the minimum permitted, dry running
- Explosive and/or fire hazard areas
- Dust, sandstorms
- Earthquakes

Special safety measures are also necessary when the liquid that goes through the pump is for example:

- Flammable
- Corrosive, abrasive
- Poisonous
- Crystallizing
- Solids-containing
- Gas-containing

You must follow the safety and operation instructions. If these are not followed, a risk to the personnel and the environment is possible, for example:

- Failure of important functions of the pump and/or plant
- Failure of specified procedures of maintenance and repair
- Risk of electrical, mechanical and chemical hazards to the personnel
- Environmental risk because dangerous material is released

2. SAFETY OF MACHINERY

2.1 General

The supply does not include the design of the operation environment of the machine, the power circuits, control circuits and controls of machine operation. However, the European Machinery Directive 2006/42/EC on the safety of machines and/or related national legislation of the country where the machine is used are mandatory related to the necessary health and safety requirements in the operation of the process.

It is necessary that the Customer has taken into account the necessary requirements that are shown in this instruction when designing, purchasing and starting up the process control systems, other controls and equipment related to the machine. Some of these requirements are also applicable to the personnel that operate the machine.

As far as the above is applicable, the Customer must also follow the appropriate legislation on electrical safety (such as the low-voltage directive 2014/35/EU) or electromagnetic compatibility of equipment (EMC directive 2014/30/EU). During the operation of the machine you must also follow the appropriate occupational safety legislation of the country where the machine is used.

2.2 Necessary health and safety requirements

2.2.1 General remarks

2.2.1.1 Definitions

When necessary, the potential dangerous areas related to the machine and its operating environment, persons working in the dangerous areas and all operator groups of the machine must be specified together by the Customer and the Manufacturer. This may be necessary for example because of operation training arranged for the operators of the machine.

2.2.1.2 Principles of safety integration

To ensure safety integration, as a machine manufacturer we follow the Machinery Directive and/or the national legislation of the country where the machine is used as far as the supply is concerned. The installation, operation and safety instructions supplied with the machine must be followed in the reception of the machine, in installation and in operation. Before actual start-up, make sure that the machine, its controls and other equipment related to the safe operation of the machine comply with the requirements given in the Machinery Directive and/or in national safety legislation.

2.2.1.3 Materials and products

The products related to the use of the machine (such as liquids transferred in the process) must not endanger the exposed persons' safety or health. The process where the machine is used must be designed so that the use of liquids causes no hazard.

2.2.1.4 Lighting

Maintenance areas necessary for the regular inspections of the machine must have appropriate lighting.

2.2.1.5 Design of machinery to facilitate its handling

The environment of the machine must enable the moving of the machine or its components safely. If necessary, the upper part of the machine can be attached to standard lifting equipment. You must fully follow the moving and lifting instructions supplied with the machine.

2.2.2 Controls

2.2.2.1 Control and stopping devices

It must be possible to use the controls of the machine safely, and the controls must be designed in a manner that will prevent a dangerous situation from occurring.

Follow the specified requirements related to controls, starting devices, stopping devices (including emergency stop devices) and selection of control and operating modes for the machine and combinations of machinery. Refer to the Machinery Directive and/or the national legislation of the country where the machine is used.

The controls of the machinery must be able to prevent fluctuations in energy supply or failures in the control circuit, potentially causing dangerous situations. The interactive software used in the controls between the operator and the machine must be easy to use.

2.2.3 Protection against mechanical hazards

2.2.3.1 Stability

You must follow fully the installation instructions supplied with the machine. This is to make sure that the machinery is sufficiently stable.

2.2.3.2 Risk of damage during operation

The piping and hoses connected to the machine must be resistant to the internal and external forces. They must be tightly attached and must withstand all loading and forces.

During operation, there is always a risk of damage to the piping connected to the machine (risk of high-pressure/hot/harmful liquid spray) if the supplied instructions are not followed.

2.2.3.3 Risks because of falling or ejecting objects

Follow the necessary precautions to prevent objects from falling or ejecting (e.g. tools used during installation).

2.2.3.4 Risks because of sharp edges or angles

Because of the functioning and design of the machine, its parts have sharp edges and/or angles. During installation and maintenance, follow the instructions supplied with the machine and use the applicable personal protective equipment.

2.2.3.5 Risks related to changes in the rotational speed

The instructions supplied with the machine show the usual rotational speed of the machine and its maximum rotational speed limits. Follow these instructions when you select the rotational speed of the pump.

2.2.3.6 Risks related to moving parts

The installed guards used to prevent risks related to moving parts in the machine must be fully in position when the machine is in operation. If guards are not included in the supply, make sure before start-up that the rotating parts have protection. Also refer to the applicable legislation.

If rotating parts of the machine do not move freely during operation, stop the machine immediately. Find out the cause of the failure. Refer to the instructions supplied with the machine.

2.2.4 Protection against other hazards

The electrical drives of the machine must have a design that prevents all electrical hazards. Follow the specified rules and applicable legislation related to electrical equipment. The electrical equipment related to a machine that complies with the Machinery Directive must follow the requirements shown in standard EN 60204-1:2006.

2.2.4.1 Static electricity

The build-up of potentially dangerous electrostatic charges in the machine and its auxiliary equipment must be prevented or restricted.

2.2.4.2 Errors of fitting

Errors made when you install parts of the machine can be a source of risk. Because of this, follow fully the instructions supplied with the machine during the installation and repairs of the machine.

Incorrect liquid and electrical connections can also be a source of risk. With liquid connections, follow the instructions supplied with the machine. Incorrect electrical connections must not be possible or information on the risk must be marked on cables and connectors.

2.2.4.3 Very high temperatures

If necessary, the machine must have warnings related to high surface temperatures. In these conditions, the risk of injury caused by touching of the machinery parts must be decreased. Because of maintenance it is necessary to heat of some parts before installation. Be careful during installation, and use applicable personal protective equipment.

2.2.4.4 Fire and explosion

Correct and accurate information on the process and the functioning of the machine are necessary for the safe operation of the machine. The special conditions at the point of operation must always be examined between the Customer and Manufacturer when the machine is selected.

2.2.4.5 Noise and vibration

Noise level (dB [A] 1m) will be informed if needed. Follow the data given and do the necessary steps to prevent risks caused by noise or vibration in the operating conditions.

2.2.4.6 Radiation

The operators of the machine must fully follow the safety instructions related to the operation of this equipment.

2.2.4.7 Emissions

The instructions supplied with the machine give information on the control of leakages near the machine. If necessary, perform the following measures to prevent dangerous emissions in the process:

- determine the amount of emissions and their potential effects (e.g. possibility of fire, applicable extinguishing equipment)
- prevent the exposure of personnel to emissions
- keep the emissions under control and remove them in a controlled manner
- clean the area and machinery of emissions
- use applicable personal protective equipment and warnings

2.2.4.8 Slipping, stumbling and falling

When you install, service or repair the machine, follow the safety instructions applicable at the point of operation and the instructions supplied with the machine and be sufficiently careful to prevent slipping, stumbling or falling.

2.2.5 Maintenance

2.2.5.1 Machinery maintenance

Follow the maintenance and repair instructions supplied with the machine. The instructions tell you when it is necessary to stop and potentially drain the machine before maintenance. Wear applicable personal protective equipment that is necessary for the maintenance task:

- hearing protectors
- eye protectors
- breathing protectors
- safety gloves, safety footwear, protective clothing

When you service or repair the machine, follow the principles of ergonomics (do not use too much muscular power, use lifting equipment, lifting positions, lighting of the area, cleanliness etc.)

2.2.5.2 Access to operating position and servicing points

If the supply does not include location design for the machine, install the machine in a position that enables safe maintenance and repairs of the machine.

When you design the operating environment make sure that there is sufficient maintenance space around the machine.

2.2.5.3 Isolation from energy sources

The controls of the machine must include clearly identified devices that can be used to isolate the machine from all energy sources. These devices must have locks if the re-connection of energy can be dangerous to persons. After the energy supply is cut off, it must be possible to remove the energy stored in the process (e.g. release pressure) without a health risk to persons.

2.2.5.4 Operator intervention

The controls of the machine must be designed so that the operator needs to intervene in the operation of the machine as little as possible.

2.2.5.5 Cleaning of (internal) parts of machine

Refer to the instructions supplied with the machine and the safety instructions applicable at the point of operation to do the potential cleaning of the machine safely.

2.2.6 Indications

2.2.6.1 Information and warning devices

Follow the specified requirements shown in the Machinery Directive and/or national legislation of the country where the machine is used related to information and warning devices used in the machine.

2.2.6.2 Warning of residual risks

Keep the safety warnings related to the machine clean in all conditions and replace the warnings if necessary. All operators of the machine must know the residual risks related to electricity or the controls. Refer to specified requirements shown in the Machinery Directive and/or national legislation of the country where the machine is used.

2.2.6.3 Marks and instructions

Follow the Machinery Directive and/or national legislation of the country where the machine is used in terms of the marks and instructions for the machine. Make sure that the marks and instructions for other equipment related to the safe operation of this machine comply with legislation.

Make sure that the point of operation has instructions for emergencies, such as:

- how to give alarm
- location of rescue and fire extinguishing equipment
- availability of first aid supplies and equipment

3. NECESSARY SAFETY PRECAUTION

Before you service the product, the operators and maintenance personnel must know all necessary safety precautions.



WARNING	
Always stop the drive unit before you repair the pump. * * *	
Make sure that the drive unit cannot be started during repair.	



WARNING	
Use personal protective equipment when you you service the product.	



WARNING	
Tools used in an explosive air mixture must comply with the requirements of the relevant standard. * * *	
In a potentially explosive environment, the pump must be lifted and transferred so that no sparking can occur.	



WARNING	
Remove any potentially dangerous materials from the pump before the maintenance procedures.	



WARNING	
If it is possible that there is explosive gas or vapor inside the pump or piping, clean the piping and pump with an efficient blower before you repair the pump. * * *	
If it is possible that there is explosive gas or vapor around the pump or in the servicing or repair areas, ensure sufficient ventilation around the pump during the operation and servicing of the pump.	



WARNING	
Do not expose the pump to heat when you disassemble the pump, because liquid trapped in the pump can cause a risk of explosion.	

**WARNING**

If there is a possibility of a dangerous return flow after the shutdown of the pump, install a nonreturn device in the outlet piping.

**WARNING**

All safety devices (e.g. coupling guards) must be correctly installed before you start the pump. Use guards with a non-sparking material for explosive areas.

**WARNING**

A leakage of a dangerous material can occur. Prepare the correct procedure for a safe waste removal.

**WARNING**

The parts of the pump in contact with the liquid can be very hot. Do not touch them before they are cool.

**WARNING**

The access of harmful bearing currents into the pump bearings must be prevented in accordance with the instructions of the motor and frequency converter manufacturers.

**CAUTION**

Use the product only for the purpose for it is supplied. Refer to the correct operation procedures described in these instructions.

**CAUTION**

Make sure that the product always has a shaft sealing system compatible with the pumped liquid.

**CAUTION**

Verify the correct alignment of the coupling before you start the pump.

**CAUTION**

Do not start the pump before the system and the pump is filled up with the medium and vented.

**CAUTION**

Do not operate the pump below the minimum recommended flow.

**CAUTION**

Make sure the suction valve is open during operation.

4. OPERATING CONDITIONS THAT HAVE AN EFFECT ON PRODUCT SAFETY

The operation conditions shown in table 1 always have a direct effect on product safety. Therefore, try to avoid the following problems related to the servicing or operating conditions of the product.

Table 1, Typical non-permissible operating conditions

Cause:	Consequence:
Discharge valve is closed. Suction pressure has been estimated too low when pump was selected. The pump is operated at too high a rotational speed.	Pressure increases
Discharge valve is closed. Discharge valve is not open enough. Incorrect estimate of properties of the pumped liquid when the pump was selected.	High temperatures
Failure of sealing water service - Sealing water pump not started - Sealing water valve not opened - Sealing water equipment incorrectly adjusted - Quality of the sealing water does not correspond to the requirements. Incorrect estimate of inlet pressure when the pump was selected. Pump is not correctly filled with the pumped liquid. - Suction valve not opened - Suction tank not properly filled - Suction piping resistance or air tightness incorrectly examined	High temperatures (Sealing unit)

5. TECHNICAL DATA

The individual pump technical data is found from the pump rating plate. The rating plate is stuck to the pump and to the last page of this manual.

6. STRUCTURE

The pump with the integrated motor is the set in which the impeller is mounted directly on the motor shaft. SD - pump with the IEC motor is the set in which pump shaft is connected to the motor shaft with the coupling.

The pump impeller is installed directly onto the shaft of the electric motor (no separate couplings).

Fixed speed motor:	Asynchronous motor (IE3 0,75-160kW) 400/230 V, 50 Hz 0,03–3 kW 690/400 V, 50 Hz (3)4–160 kW (Exception: L_-100S/4 3kW and AL_/AT-1129/4 3kW are equipped 690/400V motor)
Enclosure class:	IP 54 0,03–4 kW 4-poles motor: 1500 r/min 50Hz and 1800 r/min 60Hz 0,25–4 kW 2-poles motor: 3000 r/min 50Hz and 3600 r/min 60Hz IP 55 5,5–190 kW 4-poles motor: 1500 r/min 50Hz and 1800 r/min 60Hz 5,5–54 kW 2-poles motor: 3000 r/min 50Hz and 3600 r/min 60Hz
Insulation class:	F
Duty type:	S1 (continuous duty) Ambient temperature: max. +45 °C
IEC-standard electric motor:	Asynchronous motor (IE3 or IE4). Other efficiency classes and topologies on a case-by-case basis 690/400 V, 50 Hz 4-90 kW 660/380 V, 60 Hz 4-90 kW 690/400 V, 60 Hz 4-90 kW 440 V, 60 Hz 4-105 kW 460 V, 60 Hz 4-110 kW 480 V, 60 Hz 4-110 kW Note! In the data sheets, value of the nominal currents are indicated as approximate values for 400 V, 50 Hz and 380-480 V, 60 Hz. The exact values depend on the motor type, efficiency class and brand of motor. That exact values are informed in the order confirmation and motors rating plate.
Enclosure class:	IP55
Insulation class:	F
Duty type:	S1 (continuous duty) Ambient temperature: max. +40 °C

7. SAFETY SYMBOLS



Sign of danger to persons



Sign of voltage danger

ATTN

Sign of danger to safe operation of the pump and/or protection of the pump itself

8. FIELDS AND LIMITS OF APPLICATION AND USE

AE, AKN, AL, AT, KI, L, T	Clean, thin, non-aggressive liquids - circulating water for heating and cooling - water-glycol mixtures, recommendation: propylenglycol max. 40 % Nominal pressure Max. temperature	10 bar + 120°C (+ 100°C with plastic impeller)
AKNH, ALH, KIH, LH	Clean, thin, non-aggressive liquids - for higher temperature liquids Nominal pressure Max. temperature	16 bar + 120°C normal + 150°C with special seal + 180°C with quench and special seal
ALM	Aggressive, thin, not bigger solid particles containing liquids - in addition to above mentioned liquids various acids, salts, oxidizing and chemically active organic fluids - sea water Nominal pressure Max. temperature	16 bar + 120 - 180°C depending on seal construction/materials used
AEP, ALP, LP, AP	Clean, thin, slightly aggressive liquids - domestic water, oxygen rich waters - sea water Nominal pressure Max. temperature	10 bar + 120°C (+ 100°C with plastic impeller)
ALS, LS	Aggressive, thin, not bigger solid particles containing liquids - in addition to above mentioned liquids various acids, salts, oxidizing and chemically active organic fluids Nominal pressure Max. temperature	16 bar + 120 - 180°C depending on seal construction/materials used
ALX, LX	Aggressive, thin, not bigger solid particles containing liquids - in addition to above mentioned liquids various acids, salts, oxidizing and chemically active organic fluids - sea water Nominal pressure Max. temperature	16 bar + 120 - 180°C depending on seal construction/materials used

KD	Clean, thin, non-aggressive liquids - heating and cooling circulating systems - water-glycol mixtures, recommendation: propylenglycol max. 40 %	
	Nominal pressure Max. temperature	10 bar +110°C
K, KM	Aggressive, low viscosity, not big solid particles containing liquids - in addition to above mentioned liquids various acids, salts, oxidizing and chemically active organic fluids	
	Nominal pressure Max. temperature	10 bar +110°C

ATTN

Suitability of materials and seals for pumped liquid shall be always checked between purchaser and supplier.

9. SAFETY PRECAUTIONS: HANDLING, TRANSPORT AND STORAGE OF THE PUMPS

You can find the total gross and net weights of the supply in the packing list attached to the product or packing.



WARNING
Observe all instructions regarding lifting and transport to prevent crashing of the box or assembly.

Make especially sure that these items are stable:

- Pump
- Spare parts.

Always ascertain the center of gravity of these items before you lift or transfer the pump.

Use personal protective equipment such as helmet, safety shoes and gloves.

If the proper lifting equipment is not available, transfer heavy assemblies with for example skids on the ground level.

Lifting accessories must have the identification of the manufacturer, material and the maximum working load.

Lifting ropes used directly for lifting or holding the pump or pump unit must not include splicing other than at their ends. Textile ropes and slings must not include knots, connections or splicing other than at the ends of the sling. This is not applicable to an endless sling.

Make sure that the lifting accessories can always sufficiently suspend the lifted assembly.

There must be a sufficient quantity of lifting ropes. Adjust them correctly to prevent damage to the product when you lift it. A lifting chain must not touch the product during lifting (if it does, the painted and machined surfaces can be damaged).



VARNING
Make sure that accepted and undamaged ropes and lifting accessories are available. The lifting capacity of the lifting accessories and ropes must correspond to the weight of the items you are lifting.



VARNING
In a potentially explosive environment, the pump must be lifted and transferred so that no sparking can occur.

The heavier pumps are provided with lifting links.

Pumps shall be stored in a dry and cool place protected from dust.

In the case of longer storage time it is recommended to rotate the pump manually f.ex. from the motor fan at least once a month. When the pump serves as a stand-by or is stopped for longer time for some reason, it is necessary to start it for a while after two weeks stoppage.

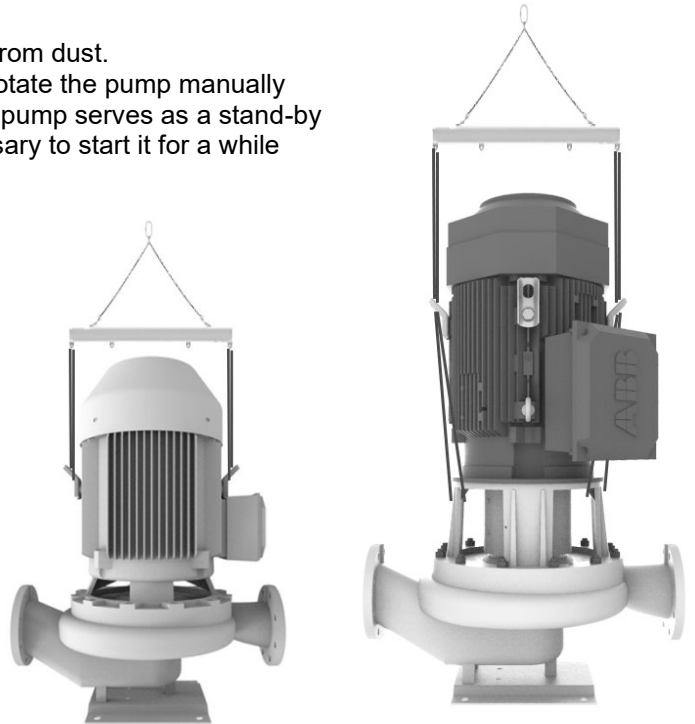

10. INSTALLATION AND START-UP

10.1 Installation

When installing the pump pay attention to the following:

- space enough for service and inspection of the pump
- possibility to use lifting mechanism if needed
- shut-off valves on the both sides of the pump

The smaller pumps (below 15 kW) can be mounted without the foot.

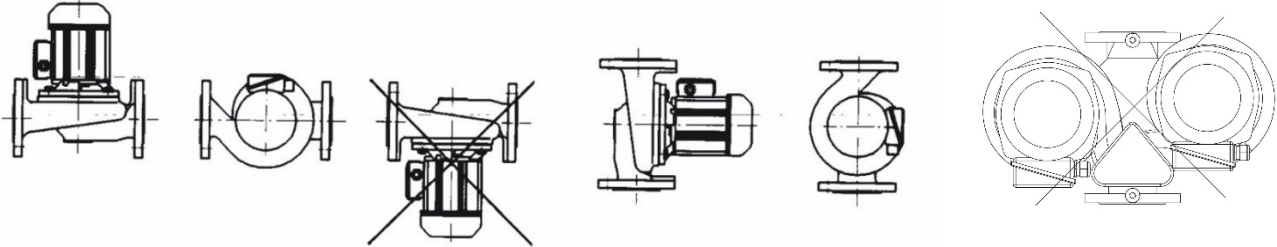

The heavier pumps should be fastened to a foundation of concrete which is isolated from the floor f.ex. with 20 mm thick gum or cork plate(s). The weight of the concrete foundation must be about 1.5 times the weight of the pump.

The position of the motor unit and the terminal box can be changed by removing the motor unit from the pump housing and setting it to the desired position (not in AKN_H, AL_H, KI_H, L_H external flushing).

10.2 Electrical wiring



All electrical work shall be carried out by an electrician approved by the power supplier.

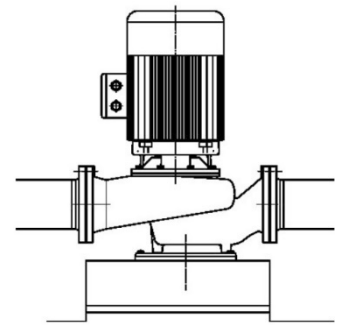

Check, that the voltage on the pump data plate corresponds to the mains voltage.

Standard connections:

Smaller motors (<4 kW)

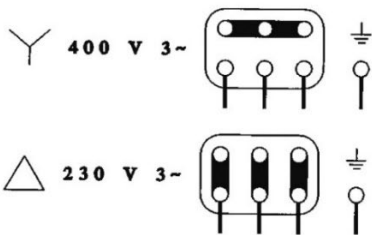

Bigger motors (≥ 3 4 kW)

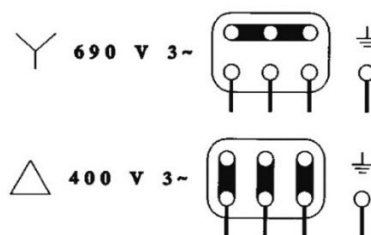

ATTN

The motor must always be equipped with an overload protection or with a frequency drive, which has been set according to maximum current I_{max} and the selected connection. The motor power supply must be designed in accordance with I_{max} current and the local regulations and conditions.

Check the direction of rotation of the pump during start-up and always after re-connection. The flow direction is indicated by an arrow on the pump housing or on fan cover

ATTN

Never start or let the pump run dry. Before starting the pump fill and vent the system. Make sure that the pump rotates freely by rotating it manually f.ex. from the motor fan.

After starting make sure that there is no extra noise coming from the pump and that no leakages appear.

ATTN

An inverter can be used for regulating the speed of rotation of the pump. An inverter must be adjusted to prevent the overload of the motor. When using the frequency converter, it is necessary to ensure an uninterrupted 360° earthing between the motor and the frequency converter. The current switch-off is to be adjusted according to rated current. Note. The use of over 50 Hz frequency may cause the overload of the motor. The motor suitability for frequency drive use must be ensured if the supply voltage is more than 500V.

11. MAINTENANCE AND REPAIR

The pump doesn't need any regular servicing.

As a shaft seal is used an adjustment free mechanical seal. It is a wearing part which has to be replaced if it starts to leak. Note that few drops leakage per hour can be quite normal especially when coolants (f.ex. glycol) are pumped.

11.1 Single mechanical shaft seal; type constructions

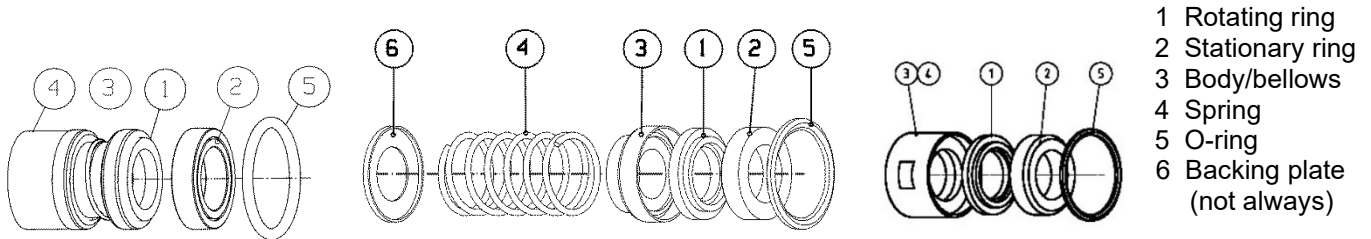

The motor is equipped with ball bearings which are lubricated for life and therefore do not need any service. In the case of any motor malfunction it is recommended to replace the whole exchange unit.

11.2 Rating plate

When ordering spare parts, please specify the pump type, serial number, duty point, the size of impeller, the motor type and power.

11.2.1 Pump with integrated motor

Material:

P = Bronze'

H = Nodular Cast Iron

S = Stainless steel

Accessories:

X = Pump without baseplate

N = Seal kit no.7

H = Recirculation

Sn = Non-standard shaft seal

Kn = Non-standard surface treatment

Vn = Special voltage

P = Single phase motor

T = External shaft seal

KT = Double shaft seal

Ln = Motor thermal protectors

En = Other difference (e.g. EXE)

Pump type

Serial number

Duty point and max temperature of liquid

Motor type

Nominal voltages, currents and

max currents

Bearing types

Pump LH-65B/2KT V1		O502103	
<small>L65B222H-00011KT V1</small>			
No 222740.100 2021 PN16 Ø 125 mm			
5,5 l/s 13 m +180 °C MEI ≥ 0,4 --			
Motor KP-90-1 F19		Isol F IP54 IE3-86,1%	
	U_n	I_n	I_{max}
690 V	2,49 A	2,9 A	3~ 50 Hz S1
400 V	4,29 A	5,1 A	cos φ 0,86
D 6305-VVC3E		N 6205-VVC3E	
Kolmek Finland			

Motor code

Pressure class and impeller diameter

Minimum efficiency index (MEI)

Enclosure and insulation class | Efficiency class of electric motor

Continuous duty

Nominal power and rotation speed

11.2.2. SD-pump

Pump type

Serial number

Duty point

Pump LH-100S/2KT SD		2103	
No 213937.4400 2021 PN 10 Ø 247 mm			
24 l/s 79 m 180 °C P2N 37,0 kW			
MEI ≥ 0,4 --			
Original Motor: M3BP 200MLB 2			
Kolmek		Finland	

Manufacturing year and month

Impeller diameter and material

Nominal power of motor

11.2.3. KI-pump

Pump type

Serial number, Pressure class

Duty point

Minimum efficiency index (MEI)

Motor type

Pump KI65-180/2		2302	
<small>KI65180211V-00010</small>			
No 123456.100 2023 PN 10 Ø 180 mm			
21 l/s 36 m +110 °C P2N 11 kW			
MEI > 0,7 --			
Original Motor: W22 160M B5T			
Kolmek		Finland	

Manufacturing year and month

Component number

Impeller diameter and material

Nominal power of motor

11.2.4. Example of rating plate for IEC-standard motor

Motor type

Rating

IE2						
3~ motor		M3AA 225 SMA 4			2014	
No.						
V	Hz	kW	r/min	A	Ins.cl F	IP 55
400 D	50	37	1479	68,0	0,84	S1
690 Y	50	37	1479	39,4	0,84	S1
415 D	60	37	1481	68,0	0,81	S1
460 D	60	37	1782	59,0	0,84	S1
<small>50Hz: IE2 - 93.4(100%) - 99.8(75%) - 99.1(50%)</small>						
<small>60Hz: IE2 - 93.6(100%) - 99.5(75%) - 92.5(50%)</small>						
D.E. 6313-2Z/C3		N.D.E 6212-2Z/C3			240 kg	
IEC 60034-1						

12. PARTS FOR PUMP

12.1 Pump with integrated motor (flanged connections)

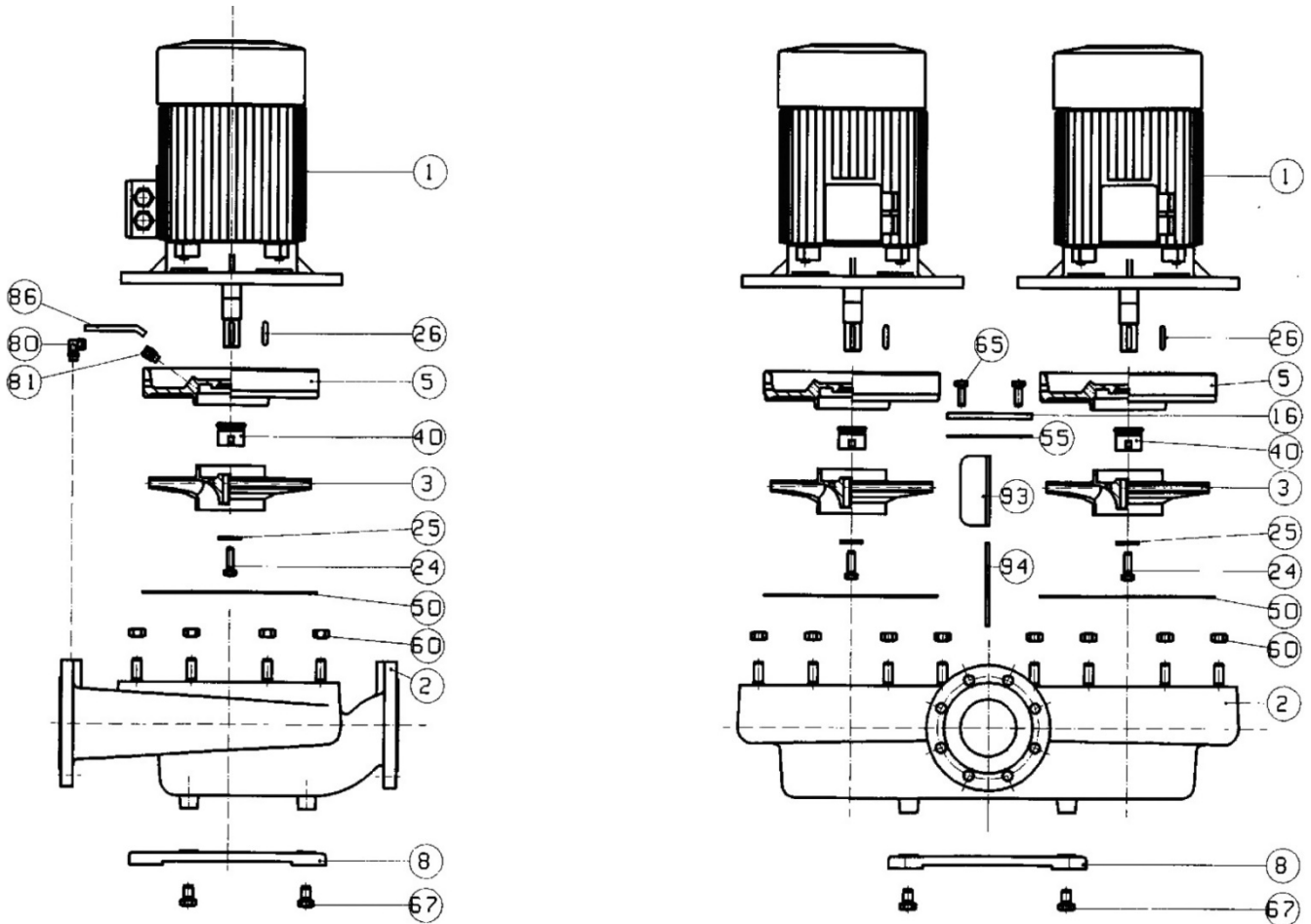

POS.NO.	DESCRIPTION		DESCRIPTION
1	ELECTRICAL MOTOR	2	PUMP HOUSING
3	IMPELLER	5	SEALING FLANGE
8	BASE PLATE (not always)	16	COVER (T- and AT-serie)
24	SCREW OR NUT	25	WASHER
26	KEY	40	SHAFT SEAL
50	O-RING	55	O-RING (T- and AT-serie)
60	SCREW OR NUT	65	SCREW (T- and AT-serie)
67	SCREW	80	PIPE UNION (Internal flushing)
81	PIPE UNION (Internal flushing)	86	COOLING PIPE (Internal flushing)
93	FLAP (T- and AT-serie)	94	CYLINDRICAL PIN (T- and AT-serie)

12.2 Pump with integrated motor (thread connections)

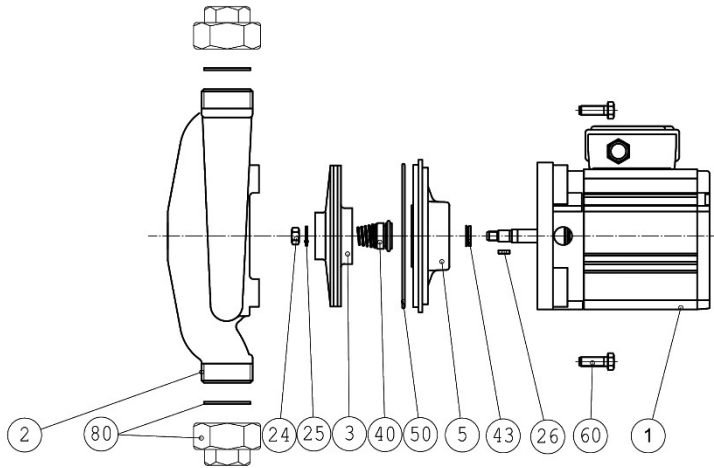

POS.NO.	DESCRIPTION
1	ELECTRICAL MOTOR
2	PUMP HOUSING
3	IMPELLER
5	SEALING FLANGE
24	NUT
25	WASHER (not always)
26	KEY
40	SHAFT SEAL
43	V-RING
50	O-RING
60	SCREW
80	PIPE UNION 2 piece

12.3 End-suction (KD, K, KM)

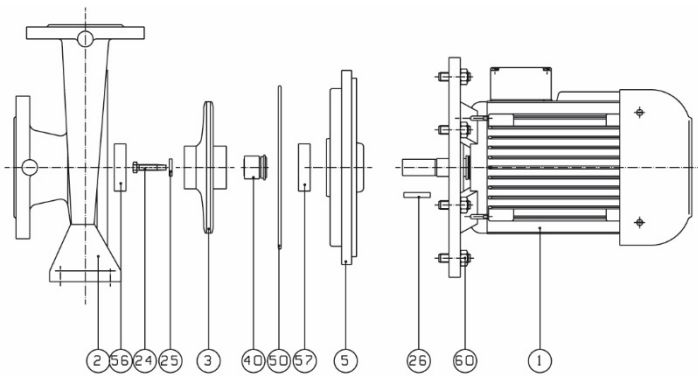

POS.NO.	DESCRIPTION
1	ELECTRICAL MOTOR
2	PUMP HOUSING
3	IMPELLER
5	SEALING FLANGE
24	SCREW
25	WASHER
26	KEY
40	SHAFT SEAL
50	O-RING
60	SCREW OR NUT

12.4 SD-pump with IEC-standard motor (flanged connections)

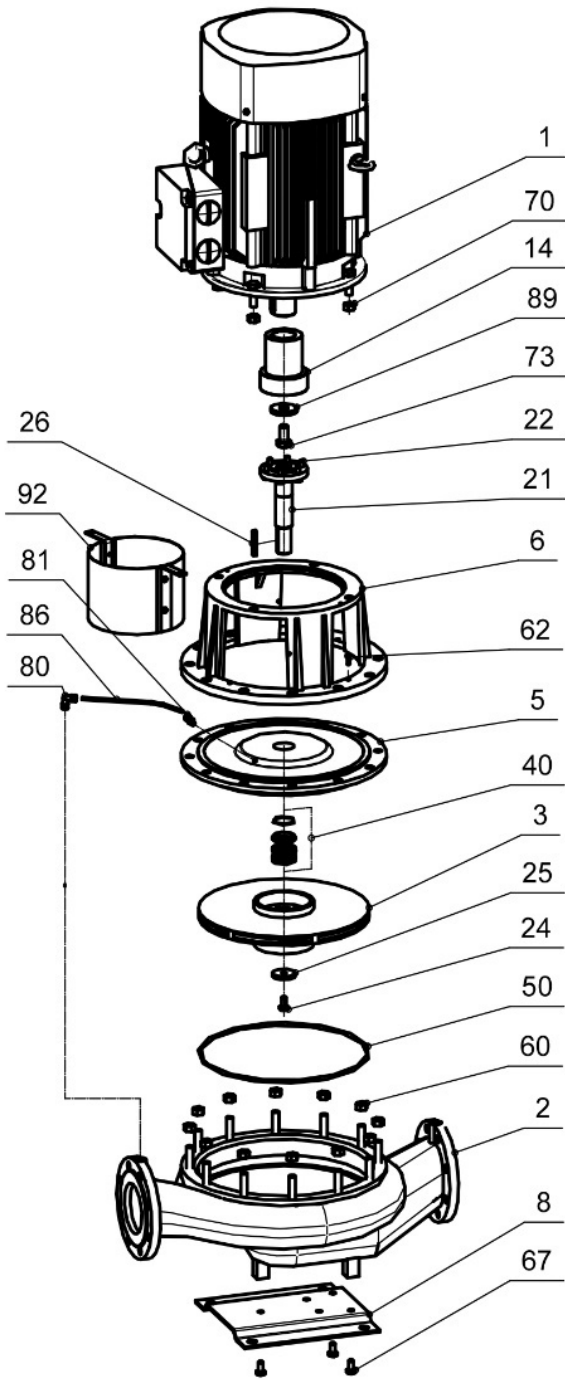

POS.NO	DESCRIPTION
1	ELECTRICAL MOTOR
2	PUMP HOUSING
3	IMPELLER
5	SEALING FLANGE
6	MOTOR BRACKET (ADAPTER)
8	BASE PLATE
14	COUPLING
21	FLANGE-SHAFT
22	SCREW
24	SCREW
25	WASHER
26	KEY
40	MECHANICAL SHAFT SEAL
50	O-RING OR GASKET
60	SCREW / NUT
62	SCREW
67	SCREW
70	SCREW / NUT
73	SCREW
80	PIPE UNION (Internal flushing)
81	PIPE UNION (Internal flushing)
86	PIPE (Internal flushing)
89	WASHER
92	COUPLING PROTECTION

12.5 IEC-standard motor (KI)

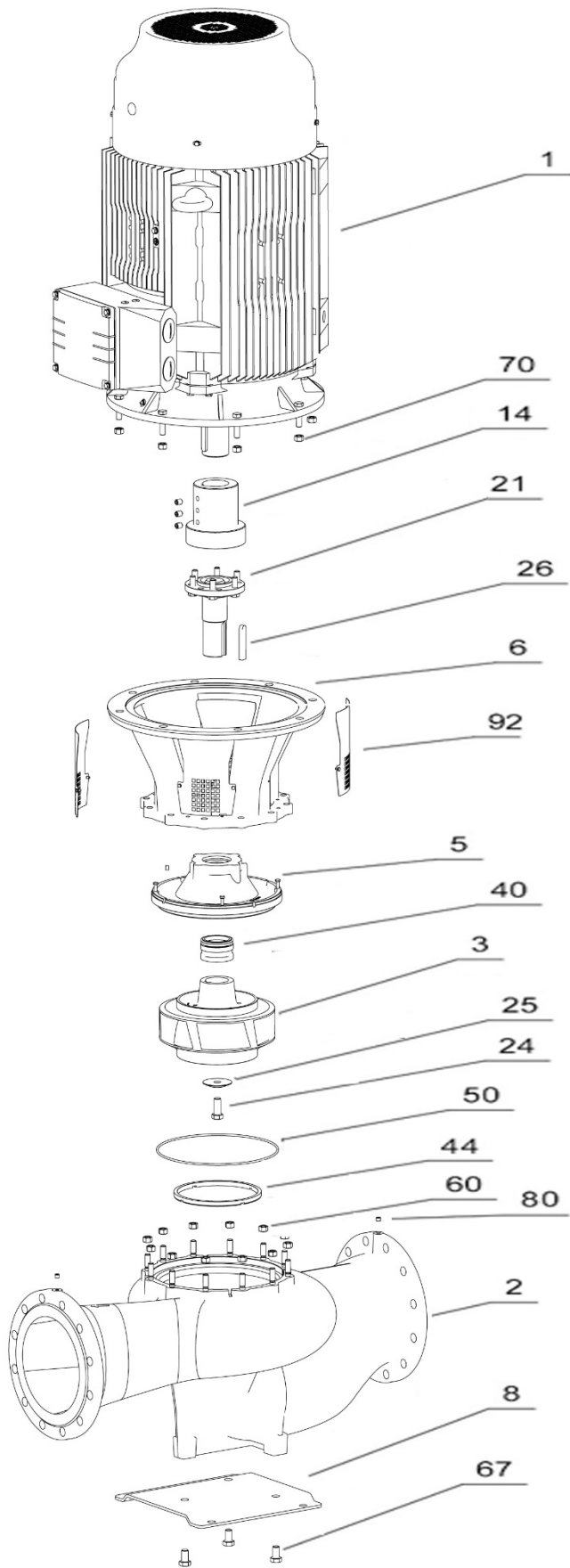

POS.NO	DESCRIPTION
1	ELECTRICAL MOTOR
2	PUMP HOUSING
3	IMPELLER
5	SEALING FLANGE
6	MOTOR BRACKET (ADAPTER)
8	BASE PLATE
14	COUPLING
21	FLANGE-SHAFT
22	SCREW
24	SCREW
25	WASHER
26	KEY
40	MECHANICAL SHAFT SEAL
44	WEAR RING
50	O-RING OR GASKET
60	SCREW / NUT
62	SCREW
67	SCREW
70	SCREW / NUT
73	RUVVI
80	PIPE UNION (Internal flushing)
81	PIPE UNION (Internal flushing)
86	PIPE (Internal flushing)
89	COUPLING PROTECTION
92	COUPLING PROTECTION

13. REPLACING EXCHANGE UNIT

13.1. Less than 1,5kW

Note! Only an authorized person may carry out the replacement.

Starting situation. The pump is running normally.



1) Stop the pump, open any possible safety switch and remove fuses. Ensure that no one is able to switch the current on, even by accident, during the replacement. Close the valves.



2) Detach the motor cable. Open the screws/nuts of the operating unit.



3) Lift the operation unit from the pump housing. Watch out for hot water!

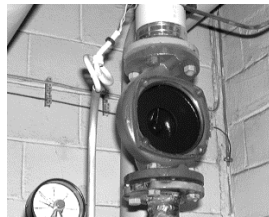

4) Replace the gasket/O-ring of the housing.



5) Install a new exchange unit. Tighten the screws/nuts of the unit evenly.



6) Connect the motor cable and open the valves. Start the pump and check the direction of rotation. Vent the system. Monitor the operation of the pump.

13.2 Over 1,5kW

Note! Only an authorized person may carry out the replacement.

Starting situation: The pump is running normally.



1) Stop the pump, open a possible safety switch and remove fuses. Ensure that no one is able to switch the current on, even by accident, during the replacement. Close the valves.



2) Close the valves and detach the connecting cable of the motor. Next, detach the flush pipe (in AKN_H, AL_H and L_H - pumps). Open the screws/nuts of the operation unit.

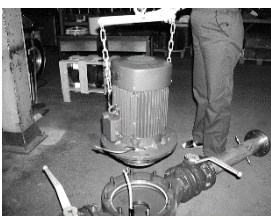

3) Lift the exchange unit by means of a hoist. Watch out for hot water!

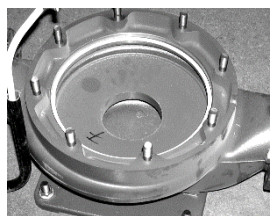

4) Replace the gasket/O-ring of the housing.

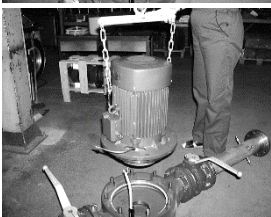

5) Install a new exchange unit. Tighten the screws/nuts of the unit evenly.



6) Connect the motor cable and open the valves. Start the pump and check the direction of rotation. Vent the system. Monitor the operation of the pump.

14. REPLACING IMPELLER



1) Detach the exchange unit as usual (see 13. Replacing exchange unit).



3) Open the screw/nut of the impeller.

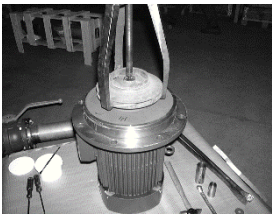

5) Use an extractor if necessary. Pull out the impeller at the impeller wings.



7) Install a new impeller. If required, you can lightly tap the impeller with a rubber mallet until flush with the ridge. Tighten the screw/nut of the impeller.



2) Install the exchange unit in a vertical position.

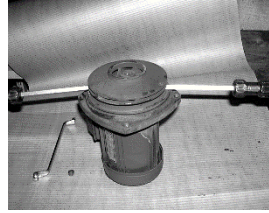

4) Use screwdrivers to detach the impeller.

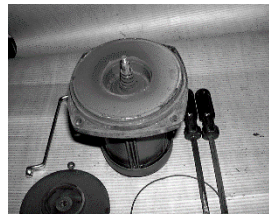

6) The exchange unit is without an impeller. Replace the shaft seal when necessary (see 16. Replacing shaft seal).



8) Attach the exchange unit as usual.

In the twin pump installation it is possible to substitute the damaged unit by a blind cap (to be ordered separately). The other unit can be driven then normally.

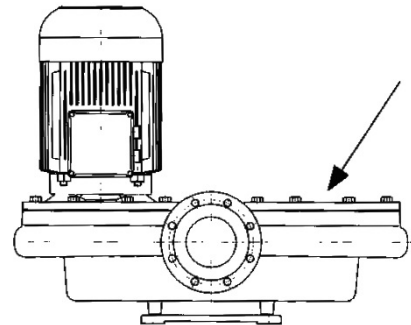

15. REPLACING IEC-STANDARD MOTOR

Starting situation: The pump is running normally.



1) Stop the pump, open a possible safety switch and remove fuses. Ensure that no one is able to switch the current on, even by accident, during the replacement. Close the valves and detach the connecting cable of the motor. Next, detach the flush pipe (in AKN_ H, AL_ H KI_ H and L_ H -pumps). Open the screws/nuts of the operation unit.



2) Lift the exchange unit by means of a hoist. Watch out for hot water!



3) Open the screw/nut of the impeller. Use an extractor if necessary.



4) Detach the shaft seal



5) Detach sealing flange.



6) Detach motor bracket (adapter) from electric motor.



7) Detach flange-shaft.



8) Detach coupling from the motor shaft.

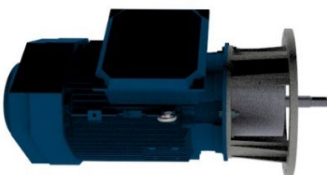

9) Install coupling, flange-shaft and motor bracket to new motor. Use threadlocker Loctite 2701.



10) Align flange-shaft using a measuring gauge. The max. allowed run-out is 0.08.

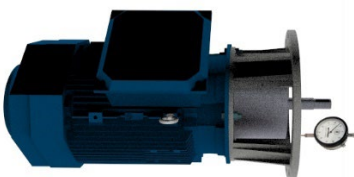

11) Align the flange perpendicularity run-out to motor shaft using a measuring gauge. The max. allowed run-out is 0.15.

12) Assemble the exchange unit by the reverse order of steps 1 to 5.

16. REPLACING SHAFT SEAL

16.1 Detaching seal

Stop the pump and close the shut-off valves. Detach the exchange unit from the pump housing. (see 13. Replacing exchange unit). Detach the impeller of the pump (see 14. Replacing impeller).

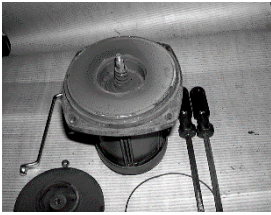

1) Starting situation. The motor unit with the impeller detached.

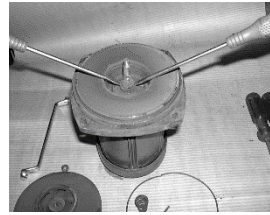

2) Detach the shaft seal using two screwdrivers. Do not damage the sealing surface of the shaft.

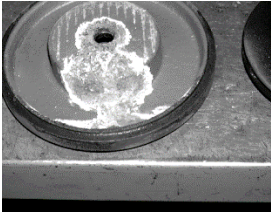

3) Also detach the sealing flange from the motor front plate using two screwdrivers. If needed, replace the sealing flange with a new one.



4) The motor unit disassembled, with installation tools.

16.2 Installing mechanical seal

16.2.1 Lubricating and installing O-ring

NOTE! Touch the seal parts with clean hands only, and as little as possible and with extreme care.

Check the housing and O-ring groove for the stationary ring in the sealing flange are clean. Check the O-ring and lubricate it with soap water, not with oil. Then install the O-ring in the groove of the sealing flange (in the stationary ring for BO- and BP-marked seals).

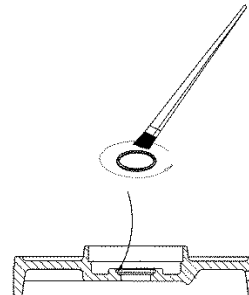
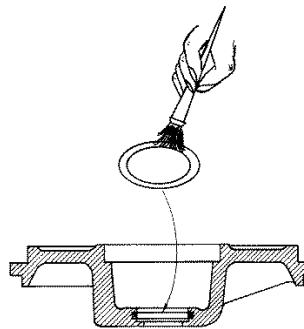

16.2.2 Pressing stationary ring into the sealing flange

Check that the stationary ring is undamaged, clean, smooth and not scratched. If the stationary ring is packed in protective foil, detach it with a knife, carefully minding the rotating surface. Then, remove the grease with a dry and clean cloth. Press the stationary ring into the sealing flange with the smoother surface facing you (the pump). Ensure that the O-ring does not push the ring out. If this happens, use more lubrication. Finally, clean the rotating surface of the stationary ring with a clean and lint-free cloth or towel which is dampened with a suitable organic solvent, e.g. methyl alcohol or spirit. Alternatively, the stationary ring can be installed with a clean lint-free cloth without fingers touching the rotating surface. Finally, the rotating surface should be blown clean with compressed air.

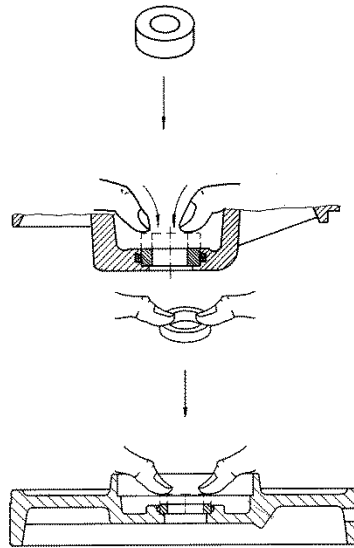

16.2.3 Installing sealing flange onto D-end motor flange

Install the sealing flange onto the motor. Place the assembly sleeve of the installation tool so that it forms a shaft extension. In large pumps, first install the sealing flange onto the motor and then the stationary ring (BO- and BP-marked seals).

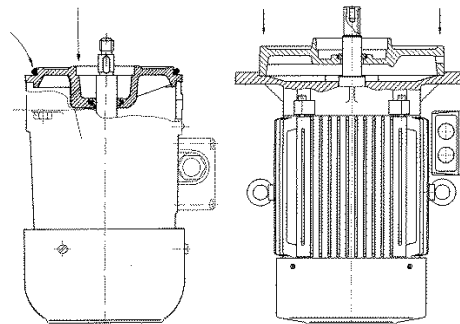

16.2.4 Assembly sleeve as shaft extension

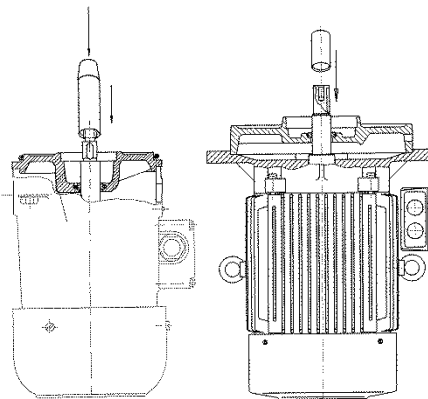

16.2.5 Soaping assembly sleeve

Check that the seal body, bellows and rotating ring are clean and undamaged. If the rotating surface of the rotating ring is dirty, clean it with a clean and lint-free cloth which is dampened with a suitable organic solvent, e.g. methyl alcohol or spirit. Lubricate the shaft and the seal elastomer bellows suitably with soapy water, not with oil.

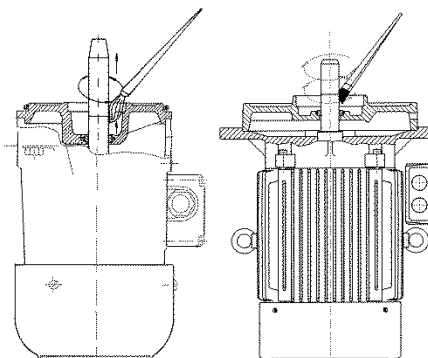

16.2.6 Pushing bellows onto shaft

Detach the spring (if separate) and, using even pressure, push the bellows onto the shaft using the installation mandrel until the rotating surfaces meet. Do not press too hard. If the spring is attached to the frame, install the whole seal onto the shaft from its bellows part (end of seal) by pushing with a suitable sleeve. If the rotating ring of the seal does not stay fast in the seal, install it first and ensure that when installing the seal frame, the frame and the rotating ring are in place correctly.

Note! Do not touch the rotating surface of the rotating ring.

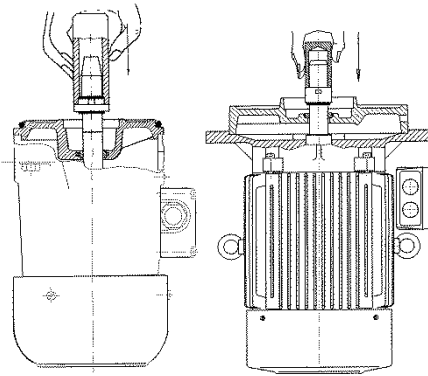

16.2.7 Installing spring, back plate and impeller

Rotate the shaft slightly and carefully and ensure that the seal fits well. Then, install spring, back plate (if separate) and impeller.

NOTE!: Never start or let the pump run dry.

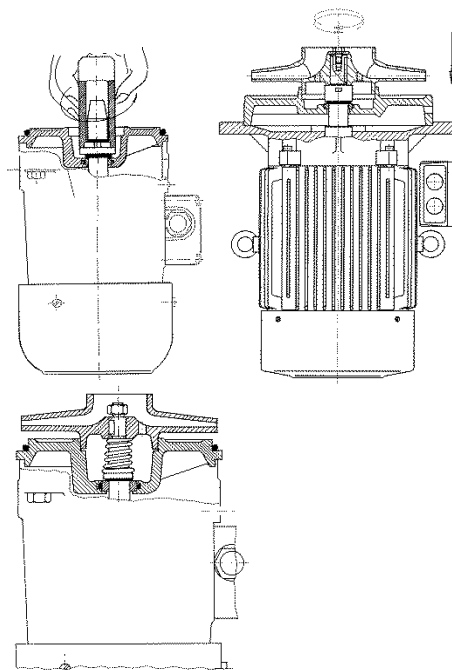

DECLARATION OF CONFORMITY

We, Kolmeks Oy, Taimistotie 2, FI-14200 Turenki FINLAND
declare under our sole responsibility for inline-pumps, to which this
declaration relates, are in conformity with the:

- | | | |
|---|--------------------------|---|
| - Machinery Directive | 2006/42/EY | |
| - EMC- directive | 2014/30/EU | |
| - Low voltage directive | 2014/35/EU | |
| - Standard | EN 809:1998+A1:2009 | Pumps and pump units for liquids. |
| | | Common safety requirements. |
| - Ecodesing directive | 2009/125/EY Regulations: | 547/2012 for water pumps
2019/1781 for electric motors |
| - RoHS- directive 2011/65/EU
and 2015/863/EU | | |

Turenki 21.06.2022



Jyrki Vesaluoma
Chairman of the board
Responsible of technical file:
Kolmeks Oy
Taimistotie 2
FI-14200 TURENKI
Finland

Kilpitarra

MINIMUM EFFICIENCY INDEX MEI

The efficiency of a pump with a trimmed impeller is usually lower than that of a pump with full impeller diameter. The trimming of the impeller will adapt the pump to a fixed duty point, leading to reduced energy consumption. The minimum efficiency index (MEI) is based on full impeller diameter.

The operation of this water pump with variable duty points may be more efficient and economic when controlled, for example, by the use of a variable speed drive that matches the pump duty to the system.

For pumps supplied after 1.1.2015 regulation 547/2012 is to be applied, Minimum Efficiency Index MEI > 0,4, benchmark for the most efficient water pumps is MEI > 0,7. Information on benchmark efficiency is available at: www.europump.org/efficiencycharts

Kolmeks Oy Taimistotie 2, PL 27, FI-14201 TURENKI, Finland P. +358 20 7521 31
sales.finland@kolmeks.com, www.kolmeks.com