

Receiver	From

Company name
Department

Phone number
Fax no.
e-mail address

Requested data

Fluid	Water	Nominal flow	l/s
Solids	Type	Nominal head	m
	Weight %	0	Static head
pH-value at t A		Available system NPSH	
Operating temperature t A °C 20		Inlet pressure	kPa 0
Density at t A	kg/m³ 998.3	Altitude	m 100
Kin. viscosity at t A cSt 1.005			
Vapour pressure at t A kPa 2.34			

Pumpe

Pumpenbezeichnung	L-100S/4MD 7.5kW				
Pumppu- ja positionumerot					
Frame size					
Design	In-line pump with frequency converter MD				
Weight	213				
Self-suctioning	<input type="checkbox"/> Yes				
Speed	1/min	3600			
Max. operating pressure	kPa	304	Flow		
Max. diff. pressure	kPa	304			
No. stages		1			
No. diffusers		1	Head		
Suction port	Pressure rating			Nominal	m
	Nominal pipe size			@ Qmax	m 18.7
Discharge port	Standard			@ Qmin	m 31.1
	Pressure rating		Head H(Q=0)	m 31.1	
	Nominal pipe size		NPSH 3%	m	
	Standard		Shaft power	kW	
	Pressure rating		Max. shaft power at max. impeller	kW 7.42	
	Nominal pipe size		Efficiency		
	Standard				

Materials

Pump parts

Pump	Pump: Grey cast iron PN10	Shaft seal	Standard seal
Impeller	Cast iron		

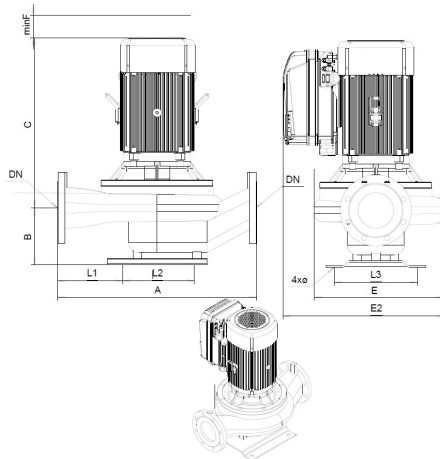

Dimensions mm

A	660
B	173
C	605
DN	DN100
E	445
E2	560
L1	208
L2	270
L3	270
minF	250
Ø	22

Motor

Coupling

Type	Kolmeks KP-134 H2 F31 7,5kW			Type	
Specific design	3-phases motors / 50 Hz / Pole pairs 2			Series	
Rated power	kW 7.5	Speed	1/min 1500	Spacer length	mm
Electric voltage	V 3~ 400	Electric current	A 13.6	Frame size	
Degree of protection	IP 55	Frame size	134	Max input current	
Type of protection	--	Explosion protection		Max input current	

Remarks:

Performance curves

Revision number

Page 2

L_-100S/4 MD 7,5kW

Customer

Supplier

Company name
Dept.
Editor
Phone number
Fax no.
E-mail

Impeller	mm	Flow Value range			Head		Shaft power P2			Impeller type	
		Min. l/s	Max. l/s	Max. l/s	m	Max. m	kW	kW	Max. kW	Impeller construction	
Actual	270	0	28	25.4	31.1	21.8	4.06	7.42	7.77	Outlet width	mm
Min.	270			9.85	3.49	3	0.16	0.46	0.347	Frequency	50 Hz
Max.	270			25.4	31.1	21.8	4.06	7.42	7.77	Speed	1/min 3600

Power data referred to: ; 20°C; 998.3kg/m³; 1.005cSt

Reference no.
Frame size

Tolerance according to: No testnorm defined for this product

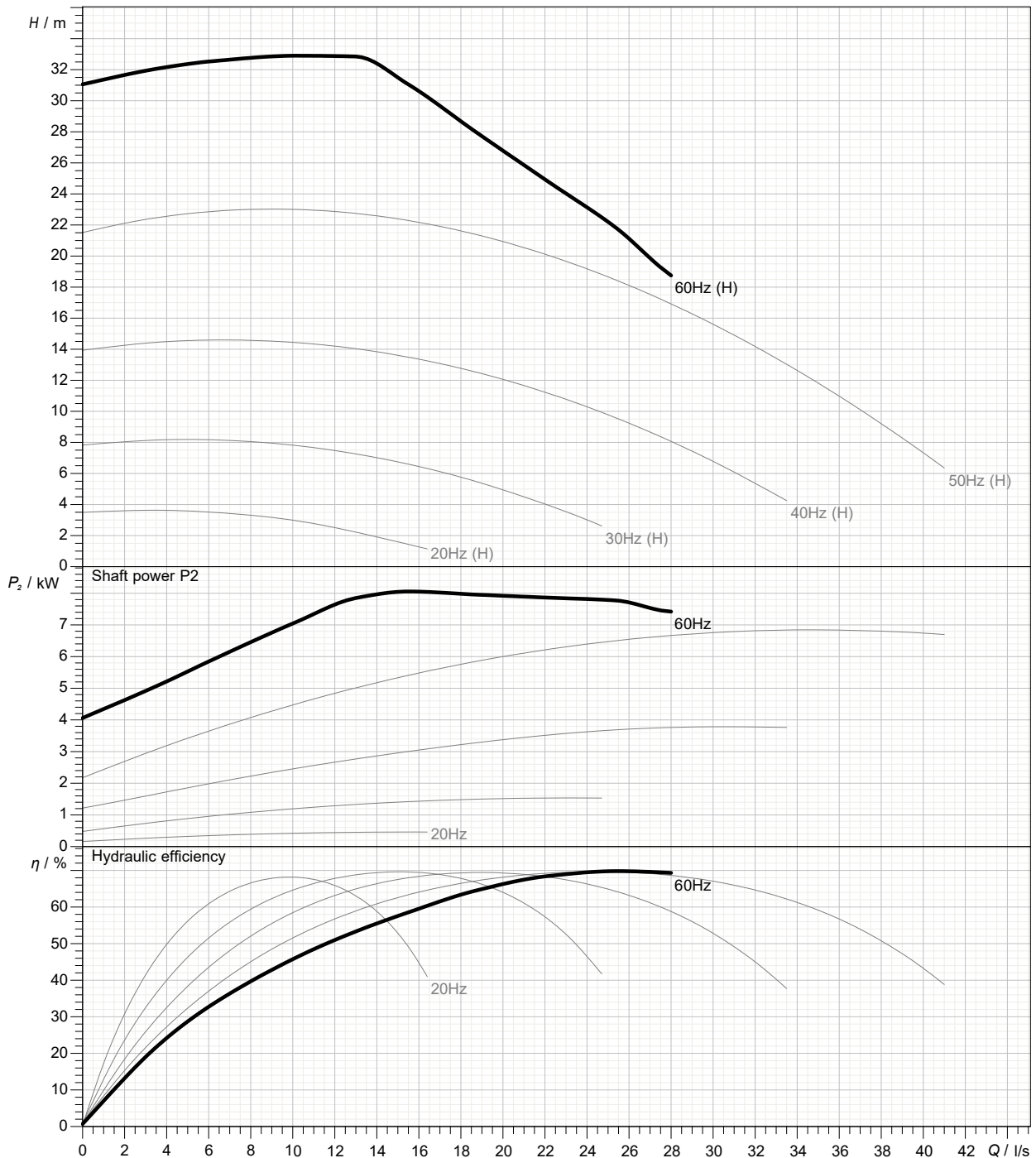

Project

Business process ID

Issue date
2022-09-07

Last update
2022-09-07