

INSTALLATION AND OPERATING INSTRUCTIONS CENTRIFUGAL PUMPS WITH INTEGRATED FREQUENCY DRIVE MD-SERIES

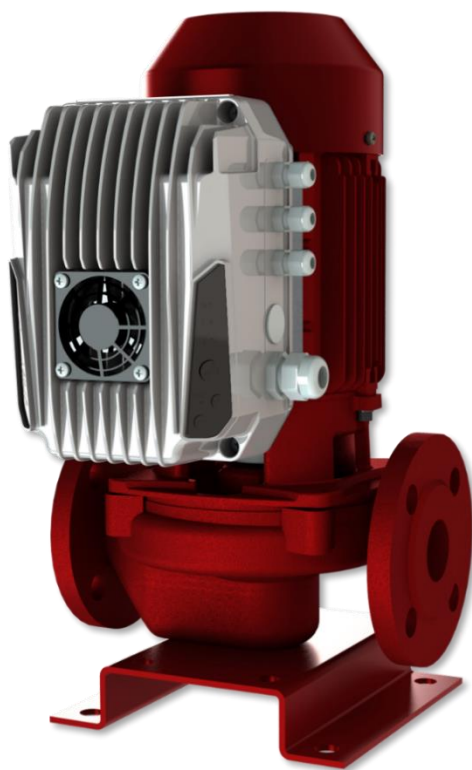

Nastec NOW / AppStore



Nastec NOW / Google play

Contents

1. General.....	4
1.1 Symbols	4
1.2 Fields of applications.....	4
1.2.1 AE-, L-, AL- pumps.....	4
1.2.2 AEP-, LP-, ALP- pumps	4
1.2.3 LH-, ALH- pumps	4
1.2.4 LS-, ALS- pumps.....	4
1.3 Limits of application and use	5
1.4 Manufacturer	5
1.5 Version	5
2. Handling, transport and storage of the pump	5
3. Design and function	6
3.1 Construction	6
3.2 Technical data	6
3.3 Pump identification	11
4. Safety	12
4.1 Safety instructions	13
4.2 Training	13
4.3 Elements of danger if safety regulations are not obeyed.....	13
4.4 Safety instructions for inspection and assembly	13
4.5 Operating the pump.....	13
5. Installation, introduction and start-up.....	13
5.1 Positions for installation	14
5.2 Electrical connections.....	14
5.3 Using MD-pump with Nastec Now mobile application or locally from keypad.....	15
5.4 Control methods	16
5.4.1 MDA-pump – Frequency reference for frequency converter	16
5.4.2 MDB- pump – constant pressure between the pump flanges	17
5.4.3 MDC- pump - constant pressure in between inlet- and outlet-line.....	19
5.4.4 MDD- pump - constant pressure in discharge (pressure boosting)	20
5.4.5 MDF- pump - constant temperature	21
5.4.6 MDG- pump - controlled by external system.....	21

6. Service, spare parts and troubleshooting	22
6.1 Shaft seals.....	22
6.2 Other parts	23
6.3 Troubleshooting.....	24
8. Annex	29
8.1 Wiring diagram MDA-single pump.....	29
8.1.1 Wiring diagram MDA-single pump, 4 x Din.....	29
8.1.2 Wiring diagram MDA-single pump, 2 x Din.....	30
8.2 Wiring diagram MDB-single pump	31
8.2.1 Wiring diagram MDB-single pump, 4 x Din.....	31
8.2.2 Wiring diagram MDB-single pump, 2 x Din.....	32
8.3 Wiring diagram MDC-single pump	33
8.3.1 Wiring diagram MDC-single pump, 4 x Din.....	33
8.3.2 Wiring diagram MDC-single pump, 2 x Din.....	34
8.4 Wiring diagram MDD-single pump	35
8.4.1 Wiring diagram MDD-single pump, 4 x Din.....	35
8.4.2 Wiring diagram MDD-single pump, 2 x Din.....	36
8.5 Wiring diagram MDF-single pump	37
8.5.1 Wiring diagram MDF-single pump, 4 x Din	37
8.5.2 Wiring diagram MDF-single pump, 2 x Din	38
8.6 Wiring diagram MDG-single pump.....	39
8.6.1 Wiring diagram MDG-single pump, 4 x Din	39
8.6.2 Wiring diagram MDG-single pump, 2 x Din	40
8.7 Wiring diagram MDM-single pump.....	41
8.7.1 Wiring diagram MDM-single pump, 4 x Din	41
8.8 Nastec Now mobile application user guide	43
8.8.1 Registering to Nastec Now user	43
8.8.2 Connecting to device and changing the set value	44
8.8.3 Changing the set value	45
8.8.4 Pump and motor monitoring	47
8.8.5 Remote use	48

1. General

1.1 Symbols



Warns that failure to observe the precaution may cause personal injury or damage to property.



Warns that failure to observe the precaution may cause electric shock.

ATTN!

Indicates something to be noted by the reader

1.2 Fields of applications

The most common applications are heating, air condition, cooling systems. Also heat exchangers, pressure boosting systems, district heating systems, ice halls, public baths and industrial processes.

1.2.1 AE_-, L_-, AL_- pumps

Clean, thin, non-aggressive liquids.

- circulating water in for heating and cooling systems
- water-glycol mixtures

1.2.2 AEP-, LP-, ALP- pumps

Clean, thin, slightly aggressive liquids.

- domestic hot water, oxygen rich waters, sea water, etc.

1.2.3 LH-, ALH- pumps

- as in L- and AL -series, but nominal pressure 16 bar

1.2.4 LS-, ALS- pumps

Aggressive, thin, not bigger solid particles containing liquids

- in addition to above mentioned liquids various acids, salts, oxidizing and chemically active organic fluids

1.3 Limits of application and use

Nominal pressure: AE-, AEP-, L-, AL-, ALP- pumps: 10 bar
LH-, ALH-, LS- and ALS-pumps: 16 bar

ATTN!



Medium temperature range: -10 ... + 90 °C

Ambient temperature: 0 ... +40°C

Suitability of materials and seals for pumped liquid shall be always checked between the purchaser and supplier. The nominal pressure and the max. temperature of pumped liquid are stamped on the pump rating plate. Never use the pump in any other application or conditions without manufacturer's acceptance. In the case of damage there may be danger to persons by having poisoning, burns, wounds etc. depending on the pumped liquid and its temperature and pressure. The pump surface temperature may cause danger depending on the working conditions.

1.4 Manufacturer

This product is manufactured by KOLMEKS OY, P.O.BOX 27, FIN-14201 TURENKI, FINLAND.

1.5 Version

Release date of this manual is 02.05.2024 This is version no. 6.

2. Handling, transport and storage of the pump

ATTN!

Normally the pumps are stable when they are transported and don't go down even, they are bent 10°. Pumps shall be stored in a dry and cool place protected from dust. Temperature of environment must be in -10 °C ... +50°C. It is not allowed to lift the pump from frequency converter. In the case of longer storage time or the pump serves as a stand-by, it is recommended to rotate the pump manually eg. from the motor fan at least once a month.

3. Design and function

3.1 Construction

The pump and motor constitute a unit, where the rotating parts of both the pump and the motor are on the same

shaft (mono-block design). The motor is of a dry type and the frequency converter is integrated to the electric motor.

Electric motor: Totally enclosed, fan cooled A.C. motor, with frequency converter.

Protection form: IP54 / IP55

Insulating class: F

3.2 Technical data

MD-pumps, variable speed drive unit with 1 X 230 V supply voltage

Pump type	Connection	Nominal power P _{2n} kW	Grid frequency Hz	Input current A max 1 x 230 V ¹⁾	Circuit breaker A ²⁾	Supply cable[mm ²] max. length 20m ³⁾	Weight kg	dB(A) 1m
AE-26/2 MD	R 1"	1,1	50 - 60	8	10	2 x 2.5 + 2.5	22	55
AE-33/2 MD	R 1 1/4"	1,1	50 - 60	8	10	2 x 2.5 + 2.5	30	55
AE-33/2 MD	R 1 1/4"	1,5	50 - 60	11	16	2 x 2.5 + 2.5	38	60
L-32A/2 MD	DN 32	1,1	50 - 60	8	10	2 x 2.5 + 2.5	29	55
L-40A/2 MD	DN 40	1,1	50 - 60	8	10	2 x 2.5 + 2.5	30	55
L-40A/2 MD	DN 40	1,5	50 - 60	11	16	2 x 2.5 + 2.5	43	60
L-50A/4 MD	DN 50	0,75	50 - 60	6	10	2 x 2.5 + 2.5	37	52
L-50B/2 MD	DN 50	1,1	50 - 60	8	10	2 x 2.5 + 2.5	37	55
L-50D/2 MD	DN 50	1,5	50 - 60	11	16	2 x 2.5 + 2.5	45	60
L-65A/4 MD	DN 65	0,75	50 - 60	8	10	2 x 2.5 + 2.5	53	52
L-65A/4 MD	DN 65	1,5	50 - 60	11	16	2 x 2.5 + 2.5	57	53
L-80A/4 MD	DN 80	0,75	50 - 60	8	10	2 x 2.5 + 2.5	59	52
L-80A/4 MD	DN 80	1,5	50 - 60	11	16	2 x 2.5 + 2.5	63	53
AL-1102/4 MD	DN 100	0,75	50 - 60	8	10	2 x 2.5 + 2.5	74	55
AL-1102/4 MD	DN 100	1,5	50 - 60	11	16	2 x 2.5 + 2.5	77	55

1) Allowed fluctuation for supply voltage +/- 15%

2) The fuse must be of type gG and the circuit breaker must follow the C or D curve

3) Longer cables should be dimensioned to consider local conditions and installation regulations.

MD-pumps, variable speed drive unit with 3 X 380-460 V supply voltage

Pump type	Connection	Nominal power	Grid frequency	Input current A max	Circuit breaker	Supply cable [mm ²]	Weight	dB(A)
		P _{2n} kW	Hz	3 x 380-460 V ¹⁾	A ²⁾	max. length 20m ³⁾		
L-50D/2 MD	DN 50	3	50 - 60	7	16	3 x 2.5 + 2.5	54	65
L-65A/4 MD	DN 65	2,2	50 - 60	7	16	3 x 1.5 + 1.5	63	55
L-65B/2 MD	DN 65	3	50 - 60	7	16	3 x 2.5 + 2.5	63	65
L-65B/2 MD	DN 65	4	50 - 60	8	16	3 x 2.5 + 2.5	67	65
L-65B/2 MD	DN 65	7,5	50 - 60	14	25	3 x 6 + 6	102	74
L-80A/4 MD	DN 80	3	50 - 60	7	16	3 x 2.5 + 2.5	69	65
L-80A/2 MD	DN 80	3	50 - 60	7	16	3 x 2.5 + 2.5	69	65
L-80A/2 MD	DN 80	4	50 - 60	8	16	3 x 2.5 + 2.5	73	65
L-80A/2 MD	DN 80	7,5	50 - 60	14	25	3 x 6 + 6	107	74
AL-1102/4 MD	DN 100	3	50 - 60	7	16	3 x 2.5 + 2.5	77	56
AL-1102/2 MD	DN 100	4	50 - 60	8	16	3 x 2.5 + 2.5	80	65
AL-1102/2 MD	DN 100	7,5	50 - 60	14	25	3 x 6 + 6	117	74
AL-1129/4 MD	DN 125	4	50 - 60	8	16	3 x 2.5 + 2.5	142	64
AL-1129/4 MD	DN 125	5,5	50 - 60	11	20	3 x 6 + 6	179	64
AL-1129/4 MD	DN 125	7,5	50 - 60	14	25	3 x 6 + 6	191	65
AL-1154/4 MD	DN 150	7,5	50 - 60	14	25	3 x 6 + 6	204	65

1) Allowed fluctuation for supply voltage +/- 15%

2) The fuse must be of type gG and the circuit breaker must follow the C or D curve

3) Longer cables should be dimensioned to consider local conditions and installation regulations.

3.2.2 Connecting the supply voltage for frequency converter MD-pumps, frequency converter with 1 X 230 V supply voltage

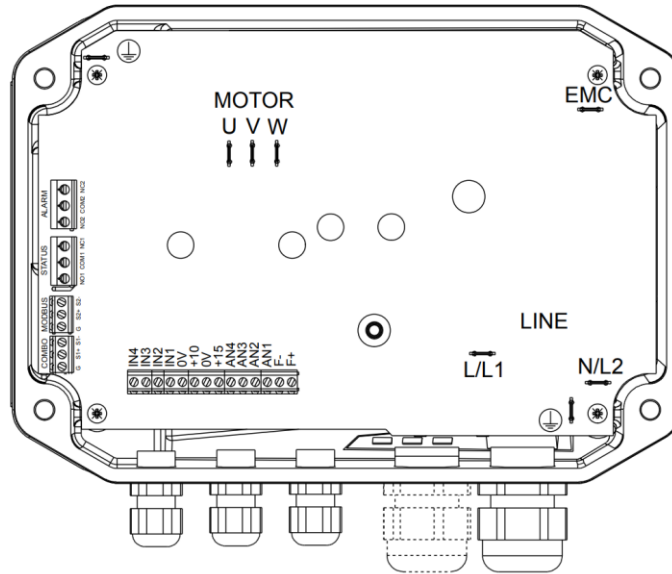

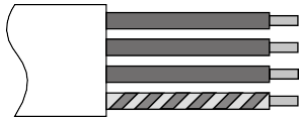
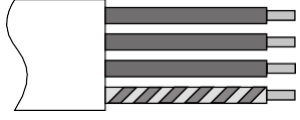
		A [mm]	Pre-insulated cable lug	stripping diagram
Power supply LINE	L1/L	70	6.3 x 0.8 mm female Faston	 <p style="text-align: center;">A</p>
	L2/N	70	6.3 x 0.8 mm female Faston	
	P.E. ⊕	70	6.3 x 0.8 mm female Faston	
Motor supply (Includes to Kolmek's delivery) MOTOR	U	120 (200)	6.3 x 0.8 mm female Faston	<p>Wall installation</p>  <p style="text-align: center;">A</p> <p>Installation on board the motor</p> <p style="text-align: center;">(A)</p>
	V	120 (200)	6.3 x 0.8 mm female Faston	
	W	120 (200)	6.3 x 0.8 mm female Faston	
	P.E. ⊕	180 (200)	6.3 x 0.8 mm female Faston	

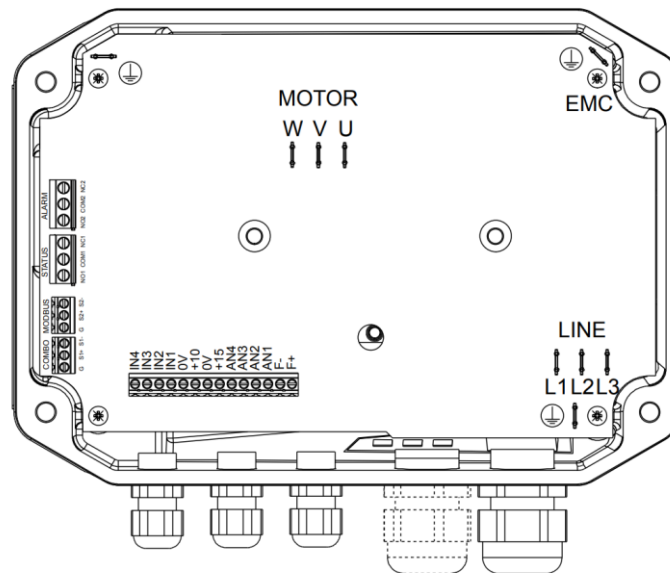
MD-pumps, frequency converter with 3 X 380 – 460 V supply voltage 0,9 – 4,0 kW

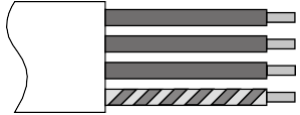
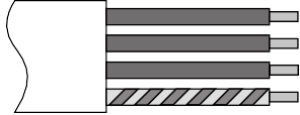
		A [mm]	Pre-insulated cable lug	stripping diagram
Power supply LINE	L1	70	6.3 x 0.8 mm female Faston	 <p style="text-align: center;">A</p>
	L2	70	6.3 x 0.8 mm female Faston	
	L3	70	6.3 x 0.8 mm female Faston	
	P.E. ⊕	70	6.3 x 0.8 mm female Faston	
Motor supply (Includes to Kolmek's delivery) MOTOR	U	120 (200)	6.3 x 0.8 mm female Faston	 <p style="text-align: center;">A</p> <p style="text-align: center;">Installation on board the motor</p> <p style="text-align: center;">(A)</p>
	V	120 (200)	6.3 x 0.8 mm female Faston	
	W	120 (200)	6.3 x 0.8 mm female Faston	
	P.E. ⊕	180 (200)	6.3 x 0.8 mm female Faston	

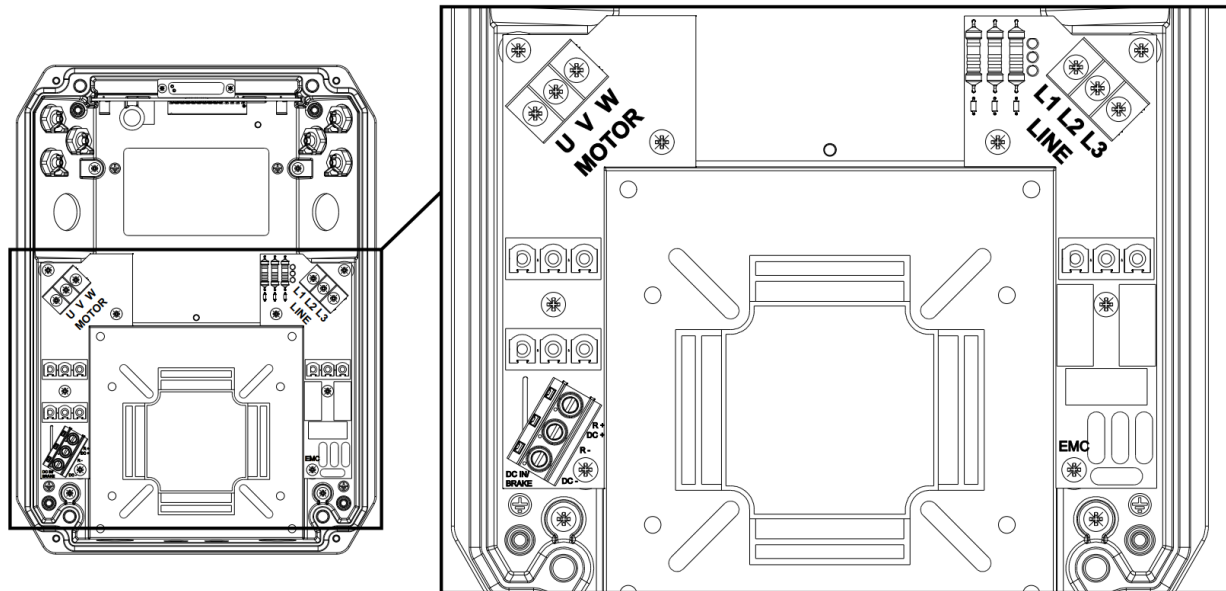
MD-pumps, frequency converter with 3 X 380 – 460 V supply voltage 0,9 – 4,0 kW

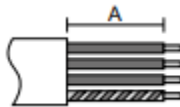
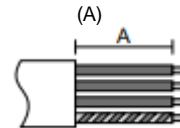
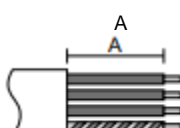
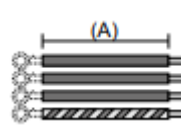
		A [mm]	Pre-insulated cable lug	stripping diagram
Power supply LINE	L1	180 (120)	Fork for M4 screw	Wall installation (through lower cable glands) A 
	L2	180 (120)	Fork for M4 screw	
	L3	180 (120)	Fork for M4 screw	
	P.E. ⊕	180 (120)	Eyelet for M4 screw	Installation on motor (through lateral cable glands) (A) 
Motor supply (Includes to Kolmeks delivery) MOTOR	U	180 (180)	Fork for M4 screw	Wall installation 
	V	180 (180)	Fork for M4 screw	
	W	180 (180)	Fork for M4 screw	
	P.E. ⊕	180 (180)	Eyelet for M4 screw	Installation on board the motor (A) 

3.3 Pump identification

Markings for accessories:

T = external mechanical seal for aggressive medium

H = flush for mechanical seal

KT = double mechanical seal

Sn = different mechanical seal

Kn = different surface treatment





Different material of impeller:

PM = Bronze CuSn10

SS = Stainless steel AISI316

Pump type
Serial number, Nominal pressure
Duty point, Max. medium temperature
Motor type

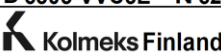
Nominal voltage and current

Pump L-50D/2 MDC		N662207	
<small>LS0D2MD15V-00003</small>			
No 225407.100-1 2022 PN10 Ø 130 mm			
6,93 l/s 9,5 m +120 °C MEI ≥ 0,4 --,-			
Motor KP-90-1 F16		Isol F IP54 IE3-86,2%	
	U_n	I_n	I_{max}
	400 V	3,22 A	5,1 A
	230 V	5,6 A	8,8 A
		cosφ 0,78	
D 6305-VVC3E		N 6205-VVC3E	
			

Motor code
Impeller size
Minimum efficiency index
Electrical power at duty point
Number of phases | Continuous duty
Insulation and enclosure class | Motor efficiency
Nominal shaft power | Motor speed
Power factor
Bearing types, CE -marking

AL - 110 2 / 4 MD B
L P - 50 B / 2 MD C

Pump series:

AE-, L-, AL-

Material of pump housing, sealing flange and impeller:

no letter = grey cast iron EN-GJL-200 / 10 bar

H = nodular cast iron EN-GJS-400 / 16 bar

P = bronze CuSn10 / 10 bar

S = stainless steel AISI 316 / 16 bar

Flange size, DN-size:

25 = 1"

32 = DN 32

40 = DN 40

50 = DN 50

65 = DN 65

80 = DN 80

1102 = DN 100

1129 = DN 125

1154 = DN 150

Poles of the electric motor:

2 = rotation speed 50 r/s (50 Hz)

4 = rotation speed 25 r/s (50 Hz)

ATTN! Motor speed is varying according to variable speed drive output frequency

MD = MD the frequency converter is integrated to the pump:

Control method:

MDA, MDB, MDC, MDD, MDF, MDG (check *Control methods and connections*)

4. Safety

This manual includes important information concerning installation and operating the pump. Persons who are involved in installation or/and operation of the pump, should read and understand these instructions before installation or starting the pump.



There are live parts inside the frequency converter of the VS -pump, when the supply voltage is connected. Incorrect installation of VS –pump may cause damage to the pump or bodily injuries, even death. Touching the live parts may be mortal even the supply voltage is disconnected. Obey instructions of this manual and national and local requirements and standards. Electric motor connection space and frequency converter motor output are under voltage, when supply voltage is connected, no matter if motor is stopped or not.

Wait at least 10 minutes after disconnecting the supply voltage before opening the cover!

- installation must be protected by fuses and insulated correctly.
- If MD-pumps Safety Extra Low Voltage (SELV) and relay output connection, automation and I/O cable gland is used other cable inlets as M12 cable glands equipped with 360° cable shield grounding, should end user isolate shielded cable metal cover for avoiding unexpected contact to Printed Circuit Board (PCB) and electric motor connection board, which are parts under voltage. In addition to previous, end user should take care of proper grounding of cable shield. In case of 4 kW and smaller MD-pumps M20 cable inlet enters the the device to Low Voltage (LV) side of PCB, where might occur dangerous voltages. M20 cable inlet is not recommended for SELV and relay output, automation and I/O connections. In case of using M20 cable inlet with 4 kW and smaller MD-pump connections, should end user take care of proper isolating the metal shield of the cable for avoiding the contact to PCB LV-side and electric motor connection board pins, which are parts under. Cable shield isolation should continue until SELV area. SELV area and LV area are marked with dotted line in the PCB.
- covers and cable inlets (with EMC cable glands) must be installed.
- 1 X 230 V supply voltage units phase connector and neutral connector need to be shielded with ferrite ring included to the delivery. This ensures fulfilling EMC C1 requirement fulfilling.

ATTN!

It is user's or certified electrician's responsibility to ensure the correct earthing and protection in accordance with applicable national and local requirements and standards.

4.1 Safety instructions

1. MD-pump must be disconnected from the mains if repair work is to be carried out. Check that the mains supply has been disconnected and necessary time has passed (at least 10 minutes).
2. The device must be connected correctly to the earth. User must be protected from supply voltage and the pump must be protected from short circuit according to the national and local requirements and standards. The overload protection is included in MD -pump.
3. Earth leakage is more than 3,5 mA. It means, that installation of supply cable must be fixed.

4.2 Training

The persons who have responsibility for installing or/and operating the pump, should be trained.

4.3 Elements of danger if safety regulations are not obeyed

If the safety regulations are not obeyed, personal injuries or damage to the pump or related devices may occur. Valid safety instructions must be obeyed.

4.4 Safety instructions for inspection and assembly

it is user's responsibility to ensure that persons who carry out inspections and installations are qualified experts and familiarized themselves with these instructions carefully.

4.5 Operating the pump

Working safety of the delivered pump and related devices can be ensured only if these devices are operated according to the section *1.2 Fields of application* and *1.3 Limits of application* and use of this manual.

5. Installation, introduction and start-up

The pump can be installed to the piping without separate supporting.

The position of the motor unit with the frequency converter can be changed by removing the motor unit from the pump housing and setting it to the desired position with certain limitations.

When installing the pump pay attention to the following:

- space enough for service and inspection of the pump
- assembly position should be considered to optimize Bluetooth connection from mobile application to the drive unit
- free visibility to the rating plate of the pump.
- possibility to use lifting mechanism if needed
- shut-off valves on the both sides of the pump
- the frequency converter is not too close hot pipes.

5.1 Positions for installation

Allowed positions

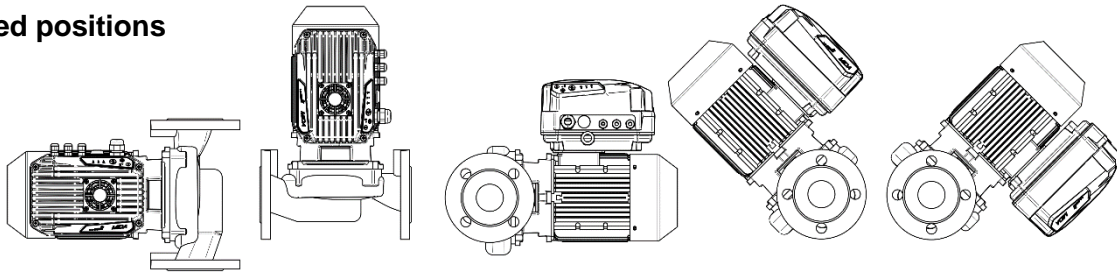

Not allowed positions

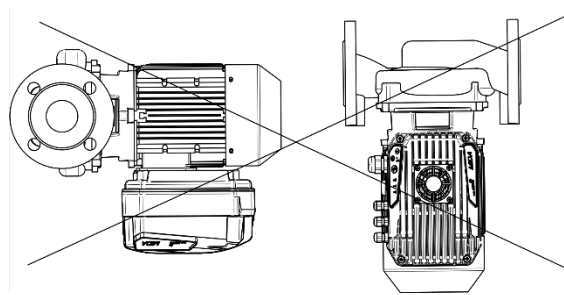

5.2 Electrical connections

5.2.1 Low voltage connections

ATTN!

All electrical work shall be carried out by qualified electrician approved by the local authorities. Supply voltage can be connected with non-shielded cable. Ensure the nominal voltage of the electric motor corresponds the local supply voltage. Kolmeks will not guarantee electric motor and frequency converter compatibility, if the user dismantles frequency converter power unit and replaces it with mechanically similar power unit. In such case power units may have different supply voltages. Check frequency converter user manual pages 11-12.

ATTN!

Before starting the pump fill and vent the system. Make sure that the pump rotates freely by rotating it manually eg. from the motor fan.

Never start or let the pump run dry. The warranty doesn't cover failures in the mechanical seal caused by dry running. Before starting the pump fill and vent the system. After starting make sure that there is no extra noise coming from the pump and that no leakages appear.

In MD-pumps exists hazardous voltages when the drive is energized. MD pump is not allowed to be used the cover removed from the bottom part.

Wait at least 10 minutes after disconnecting the supply voltage before opening the cover!

5.2.2 Safety extra low voltage (SELV) connections



In power range 0,37 kW – 4,0 kW, frequency converters MIDA205 – MIDA409 have low voltage (LV) and safety extra low voltage (SELV) connections in the same printed circuit board. MD-pump is not allowed to be used the cover, including the power board, removed from the aluminum bottom part, because there occurs hazardous contact voltages and working the cover open is working with live voltage.

Wait at least 10 minutes after disconnecting the supply voltage before opening the cover!

ATTN!

Always use screened control cables.

The shields of control cables and cable pairs should be insulated from those parts, which intersect low voltage area. The border of Low voltage and Safety extra low voltage areas is marked with white dotted line in power range 0,37 kW – 4,0 kW, drives MIDA205 – MIDA409.

The shield of control cable should be grounded either to the frame of the drive or to automation system PE rail.

Some of Kolmeks MD-pumps are equipped with metallic M12-M16 thread expander, which is connected to the frame of the drive. The shield of control cable can be grounded via metallic adapter to the frame of the drive.

In order to avoid interfering currents in the shield of control cable, it is not recommended to connect the shield to both frame of the drive and PE rail. The shields of cable pairs can be left floating, when is secured, that the shields are not in contact with parts under voltage.

5.3 Using MD-pump with Nastec Now mobile application or locally from keypad

MD-frequency converter can be controlled via Bluetooth connection with Nastec Now mobile application. Application can be downloaded from AppStore and Google Play stores free of charge. This manual contains QR-codes, which guide to application stores. Frequency converter basic operations (parametrizing and monitoring) are available without registration, but proper use of application requires registration.

In safety critical applications Bluetooth connection can be de-activated. Please contact Kolmeks representative, if the Bluetooth connection should be de-activated.

Please check instruction for registration from Appendix

Frequency converter set values (direct speed reference or PI-controller set point) can be changed from Nastec Now application or from frequency converter keypad.

In version with display is chosen with '+' and '-' buttons actual output frequency or pressure (difference) value. After this, '+'-button should be pressed 5 seconds until frequency or pressure (difference) value starts blinking. Blinking value indicates, that set value can be changed with '+' and '-' buttons to meet process requirements. After finding suitable set value, user should wait until the value stops blinking.

In version without display can be adjusted set value according to operation mode of the pump (in MDA-version frequency reference and in MDB- / MDC-versions pressure difference set value). When changing set value, '+'-button should be pressed 5 seconds until 'SET'-LED is continuously on. Continuously active LED indicates, that set value can be changed with '+' and '-' buttons to meet process requirements. Frequency reference is changed in (1) Hz steps and pressure (difference) 0,1 bar steps. After finding suitable set value, user should wait until the SET-LED stops being continuously on. This takes about 1 minute

5.4 Control methods

5.4.1 MDA-pump – Frequency reference for frequency converter

Applications

Systems, where the duty point remains constant and where is no need for continuous automated regulation.

Accessories

Pump and frequency converter.

Operation principle

Pump speed should be set in 1 Hz steps from frequency converter keypad or from mobile application. In version with display is chosen with '+' and '-' buttons actual output frequency value. After this '+'-button should be pressed 5 seconds until frequency value starts blinking. Blinking value indicates, that set value can be changed with '+' and '-' buttons to meet process requirements. After finding suitable frequency value, user should wait until the value stops blinking.

In version without display should be pressed '+'-button should be pressed 5 seconds until 'SET'-LED is continuously on. Continuously active LED indicates, that frequency value can be changed with '+' and '-' buttons to meet process requirements. After finding suitable set value, user should wait until the SET-LED stops being continuously on. This takes about 1 minute.

Frequency reference can be set also with mobile application. From proximity of controlled pump the mobile application should be connected to the frequency converter with Bluetooth connection. While connecting the mobile application and frequency converter, the passwords are 001 and 002. After connecting, the user should choose from 'Program'-menu 'control'-tab 'Operating frequency'. suitable value should be written, pressed 'OK' and finally saved to frequency converter by pressing 'WRITE'. Please note, that pump should be stopped, when values are written with mobile application.

Pump curve

QH-curve of the pump is equal with that of single speed pump.

5.4.2 MDB- pump – constant pressure between the pump flanges**Applications**

Systems, where are variations in the flow and where pressure losses are generated mainly on the consumption equipment. Heating circulation, where the pressure loss on the heat equipment is small.

Accessories

Pump, frequency converter, 2 pcs of pressure transmitters installed to the pump flanges.

Operation principle and flow adjustment

Pressure difference should be kept constant between pump flanges. The level of the constant pressure difference between the pump flanges can be adjusted by 0,1 m steps from frequency converter keypad or from mobile application.

In version with display is chosen with '+' and '-' buttons actual pressure difference value. After this '+'-button should be pressed 5 seconds until pressure difference value starts blinking. Blinking value indicates, that set value can be changed with '+' and '-' buttons to meet process requirements. After finding suitable pressure difference value, user should wait until the value stops blinking.

In version without display should be pressed '+'-button should be pressed 5 seconds until 'SET'-LED is continuously on. Continuously active LED indicates, that pressure difference value can be changed with '+' and '-' buttons to meet process requirements. After finding suitable pressure difference value, user should wait until the SET-LED stops being continuously on. This takes about 1 minute.

Pressure difference reference can be set also with mobile application. From proximity of controlled pump the mobile application should be connected to the frequency converter with Bluetooth connection. While connecting the mobile application and frequency converter, the passwords are 001 and 002. After connecting, the user should choose from 'Program'-menu 'control'-tab 'Set value [m]'. suitable value should be written, pressed 'OK' and finally saved to frequency converter by pressing 'WRITE'. Please note, that pump should be stopped, when values are written with mobile application.

Pump curve

QH-curve of the pump is controlled to a horizontal line, which is suitable for systems with low pressure loss share in heat exchanger compared to the total pressure loss.

5.4.3 MDC- pump - constant pressure in between inlet- and outlet-line

Applications

Systems, where are variations in the flow and where pressure losses are generated mainly on the source of heat equipment. Heating and cooling circulations and the pressure boosting of parallel circulations.

Accessories

Pump, frequency converter and 2 pcs of pressure transmitters. Another transmitter to be installed to the suction or pressure flange of the pump and another one on to the system inlet or outlet pipe.

Operation principle and flow adjustment

Pressure difference should be kept constant between inlet and outlet pipeline. The level of the constant pressure difference between the pipe lines can be adjusted by 0,1 m steps from frequency converter keypad or from mobile application.

In version with display is chosen with '+' and '-' buttons actual pressure difference value. After this '+' button should be pressed 5 seconds until pressure difference value starts blinking. Blinking value indicates, that set value can be changed with '+' and '-' buttons to meet process requirements. After finding suitable pressure difference value, user should wait until the value stops blinking.

In version without display should be pressed '+'-button should be pressed 5 seconds until 'SET' - is continuously on. Continuously active LED indicates, that pressure difference value can be changed with '+' and '-' buttons to meet process requirements. After finding suitable pressure difference value, user should wait until the SET-LED stops being continuously on. This takes about 1 minute.

Pressure difference reference can be set also with mobile application. From proximity of controlled pump the mobile application should be connected to the frequency converter with Bluetooth connection. While connecting the mobile application and frequency converter, the passwords are 001 and 002. After connecting, the user should choose from 'Program'-menu 'control'-tab 'Set value [m]'. suitable value should be written, pressed 'OK' and finally saved to frequency converter by pressing 'WRITE'. Please note, that pump should be stopped, when values are written with mobile application.

Pump curve

QH-curve of the pump is controlled to a quadratic. The relation of pressure loss in the source of heat (cold) to the loss in the system defines the shape of the curve. When the losses in the heat exchanger are large part of the whole losses in the system the curve is more steep.

5.4.4 MDD- pump - constant pressure in discharge (pressure boosting)

Applications

Pressure boosting or other open systems, where constant pressure is required.

Accessories

Pump, frequency converter and pressure transmitter. The pressure transmitter is installed to the pressure flange of the pump or near to the consumption in the pipe line.

Operation principle

Constant pressure should be kept in in pump outlet. The level of the constant pressure in pump outlet can be adjusted by 0,1 m steps from frequency converter keypad or from mobile application.

In version with display is chosen with '+' and '-' buttons actual pressure value. After this '+'-button should be pressed 5 seconds until pressure value starts blinking. Blinking value indicates, that set value can be changed with '+' and '-' buttons to meet process requirements. After finding suitable pressure value, user should wait until the value stops blinking.

In version without display should be pressed '+'-button should be pressed 5 seconds until `SET`-LED is continuously on. Continuously active LED indicates, that pressure value can be changed with '+' and '-' buttons to meet process requirements. After finding suitable pressure value, user should wait until the SET-LED stops being continuously on. This takes about 1 minute.

Pressure reference can be set also with mobile application. From proximity of controlled pump the mobile application should be connected to the frequency converter with Bluetooth connection. While connecting the mobile application and frequency converter, the passwords are 001 and 002. After connecting, the user should choose from 'Program'-menu 'control'-tab 'Set value [m]'. suitable value should be written, pressed 'OK' and finally saved to frequency converter by pressing `WRITE`. Please note, that pump should be stopped, when values are written with mobile application.

5.4.5 MDF- pump - constant temperature

Applications

Heating and cooling systems, where the constant temperature is required by adjusting the flow.

Accessories

Pump, frequency converter and temperature transmitter (and sensor).

Operation principle

Constant temperature should be kept in process. The level of the constant temperature in pump outlet can be adjusted by 1 °C steps from frequency converter keypad or from mobile application.

In version with display is chosen with '+' and '-' buttons actual temperature value. After this '+'-button should be pressed 5 seconds until temperature value starts blinking. Blinking value indicates, that set value can be changed with '+' and '-' buttons to meet process requirements. After finding suitable temperature value, user should wait until the value stops blinking.

In version without display should be pressed '+'-button should be pressed 5 seconds until 'SET'-LED is continuously on. Continuously active LED indicates, that temperature value can be changed with '+' and '-' buttons to meet process requirements. After finding suitable temperature value, user should wait until the SET-LED stops being continuously on. This takes about 1 minute.

Temperature reference can be set also with mobile application. From proximity of controlled pump the mobile application should be connected to the frequency converter with Bluetooth connection. While connecting the mobile application and frequency converter, the passwords are 001 and 002. After connecting, the user should choose from 'Program'-menu 'control'-tab 'Set value [°C]'. suitable value should be written, pressed 'OK' and finally saved to frequency converter by pressing 'WRITE'. Please note, that pump should be stopped, when values are written with mobile application.

NOTE! While ordering the pump, customer should announce the direction of adjustment.

Direct: when temperature actual value increases, pumping should be decreased (heating)

Reverse: when temperature actual value increases, pumping should be increased (cooling)

5.4.6 MDG- pump - controlled by external system

Applications

Systems, where are variations in the flow and/or where the flow is controlled mainly with the pump. The pump is controlled by an external system or controller.

Accessories

Pump and frequency converter.

Operation principle

The speed reference for pumps is given to Analogue input 1 (0-10 V) from external control system, external controller, process control, etc

NOTE! Pump will be stopped, when voltage signal decreases below 0,2 V.

6. Service, spare parts and troubleshooting

The pump doesn't need any regular servicing. As a shaft seal is used an adjustment free mechanical seal. It is a wearing part which has to be replaced if it starts to leak. Note that few drops leakage per hour can be quite normal especially when coolants (eg. glycol) are pumped.

6.1 Shaft seals

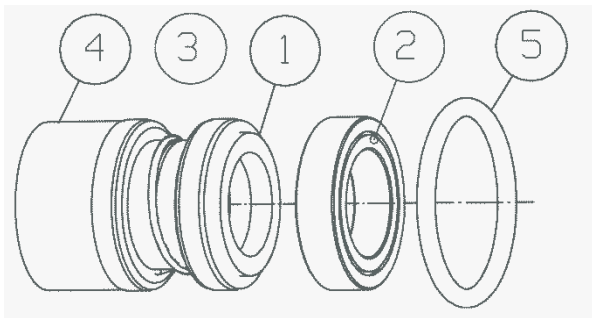

Pump type	Shaft mm	O-ring mm
AE_-25/-26 VS_	12	123x2,5
L_-32A VS_	12	100x2,5
L_-40A, AE_-32/-33 VS_	12	145x2,5
L_-50A VS_	12	150x3
L_-65A, L_-80A, AL_-1102 VS_	18	179,3x5,7
L_-100S VS_	32	315x6,3
AL_-1129 VS_	32	309/295 x 1
AL_-1154 VS_	32	309/295 x 1

- 1 Rotating ring
- 2 Stationary ring
- 3 Body / bellows
- 4 Spring
- 5 O-ring

The motor is equipped with ball bearings which are lubricated for life and therefore do not need any service. In the case of any motor malfunction, it is recommended to replace the whole motor unit.

6.2 Other parts

- 1 Electric motor
- 2 Pump housing
- 3 Impeller
- 5 Sealing flange
- 8 Foot (not always)
- 24 Screw or nut
- 25 Washer
- 26 Key
- 40 Shaft seal
- 50 O-ring or gasket
- 60 Screw or nut
- 67 Screw
- 80 Pipe union (L- and ALH -series)
- 81 Pipe union (L- and ALH -series)
- 86 Cooling pipe (L- and ALH -series)
- 103 Frequency converter
- 111 Transmitter(s) (pressure to temperature)
- 112 Quick connector of transmitter(s)

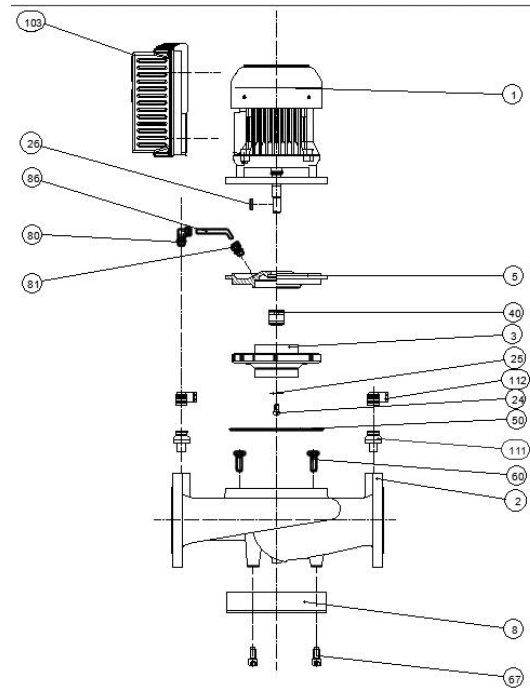

ATTN!

WHEN ORDERING SPARE PARTS, PLEASE SPECIFY THE TYPE IDENTIFICATION, SERIAL NUMBER, THE SIZE OF THE IMPELLER, THE MOTOR TYPE AND POWER AND THE POSITION NUMBER OF THE SPARE PART.

6.3 Troubleshooting

Trouble	Fault	Fixing
Shaft seal is leaking.	Wearing.	Change the seal.
	Pump has run dry.	Change the seal.
Pump doesn't run.	The shaft of the pump is blocked.	Check the free rotation of the shaft by turning the motor fan. If required, loosen the motor unit from the pump housing and repair the cause of the block.
	Fuses have worked.	Repair the cause of the fault. Change the fuses. If necessary, call the expert.
	No electricity.	Check and repair connections. If necessary, call the expert.
	The disorder has stopped the pump.	Reset the pump by disconnecting the supply voltage at least for 10 seconds.
	Control wiring is not correct.	Check the wiring in accordance with the control diagram. Between terminals 0V and IN1 must be jumpered or closed switch.
	The parameters of the frequency converter are changed or the pump is stopped locally.	Correct the parameters or start the pump locally from 'Start/Stop'-button. If necessary, call the expert.
	The frequency converter or electric motor is damaged.	Replace the frequency converter and/or electric motor with a new one. Contact to Kolmek.
ATTN!	If the pump is operated when cover of the frequency converter is open, the special carefulness must be observed.	
Pump stops by itself or runs irregular and noisy.	The supply voltage is defective. One phase is possible missing.	Check the supply voltage. Check and repair fuses and connections of the cables.
	The frequency converter or electric motor is damaged.	Replace the complete motor unit with frequency converter with a new one. Contact to Kolmek.

Trouble	Fault	Fixing
The pump is running with minimum frequency.	The reference value is missing or in minimum.	Adjust the correct value with the buttons of the local control panel or with mobile application. Check and correct the reference if the reference is given by external controller.
	The pipes of the pressure or differential pressure transducer are blocked or incorrectly connected.	Check and repair the connections and blockings of the pipes. Open the possible valves, which are installed to the pipes.
	The signal of the feedback transmitter (pressure or temperature) is too high. Possible short circuit.	Check transmitter actual value from mobile application monitoring. Check the connections, transmitter. If necessary, replace the transmitter with the new one.
	The mechanical or electrical connections of the temperature transmitter of the MDF -pump are incorrect or the transmitter is damaged.	Check and repair of the connections or the transmitter.
	Parameters of the MDF -pump are wrong (cooling and heating pumps have different parameters)	Check and correct the parameters. If necessary, call the expert.
	MDB or MDC –pump: The lower pressure transmitter gives the full signal (20 mA) or the higher pressure transmitter gives no signal.	Check the connections and transmitters. Measure the signals of the transmitter and if needed, change the transmitter.
The pump is running only with the maximum frequency, which don't vary in accordance with the requirements of flow changes.	Reference signal is too high.	Adjust the correct value with the buttons of the local control panel or from mobile application. Check and correct the reference if the reference is given by external controller.
	Feedback transmitter is missing or the signal is wrong	Check and repair the feedback signal and/or connections. If necessary, replace the transmitter with the new one.

	The pipes of the pressure or differential pressure transducer are blocked or incorrectly connected.	Check and repair the connections and blockings of the pipes. Open the valves, which may be installed to the pipes.
Trouble	Fault	Fixing
The pump is running only with the maximum frequency, which don't vary in accordance with the requirements of flow changes.	The mechanical or electrical connections of the temperature transmitter of the MDF -pump are incorrect or the transmitter is damaged.	Check and repair of the connections or the transmitter.
	Parameters of the MDF -pump are wrong. (cooling and heating pumps have different parameters)	Check and correct the parameters with the local control panel. If necessary, call the expert.
	The maximum speed is required by the system.	Check the adjustments and the need of the pumping in the system. Balance the parallel circulations. It can be the normal situation, then there is no need for any further measures. Solve the actual rotation speed by measuring or with the mobile application. Contact to Kolmeks. Maximum frequency is not allowed to change (factory default).
	MDB or MDC –pump: The higher pressure transmitter gives the full signal (20 mA) or the lower pressure transmitter gives no signal.	Check the connections and transmitters. Measure the signals of the transmitter and if needed, change the transmitter.

Trouble	Fault	Fixing
The pump is not pumping.	There is air in the pump or the system.	Deairate the system. Fill the pumps and the pipes with the fluid. Try to run the pump a moment with the high speed, then possible air pockets leave the system easier.
	The suction pressure is too low.	Increase the suction pressure.
	Circulation is closed with the valves.	Open the valves.
The pump is noisy.	Cavitation.	Increase the suction pressure. Decrease the flow.

	The pressure difference of the pump is too high.	Decrease the pressure reference. If possible, open the control valves and decrease the pressure reference, then the head of the pump is lower and the flow remains the same.
	There is a faulty shaft seal or bearings.	Continuous rough noise refers to the faulty bearings. High noise, few seconds long, occasionally refers to the faulty shaft seal. Replace faulty bearings and shaft seal with the new ones. If necessary, contact Kolmeks.
	Electrical noise from the frequency converter or electric motor.	Replace the motor with the new one. If necessary, correct the parameters of the frequency converter. Contact Kolmeks.

6.4 Checking of alarm history

Please look at frequency converter user manual page 33.

7. Declaration of Conformity

We, KOLMEKS OY, P.O.Box 27 FI-14201 Turenki, FINLAND declare under our sole responsibility that the products:

MD- - PUMP SERIE,

types AE, AEP, L, LH, LP, LS, AL, ALH, ALP, ALS

to which this declaration relates, are in conformity with the

- Council Directive 2006/42/EY on the approximation of the laws of the Member States relating to machinery
- Low voltage directive 2014/35/EU
- Pumps and pump units for liquids. Common safety requirements. EN 809:1998+A1:2009.
- Ecodesing directive 2009/125/EY Regulations: 547/2012 for water pumps
2019/1781 for electric motors
- RoHS-directive 2011/65/EU and 2015/863/EU

Serial / manufacturing number _____

EMC-STANDARDS

Generic standards

The generic standards are stated in the EMC directive (2014/30/EU).

VS_ -pump complies with:

EN 61000-6-3, EN 61000-6-1. Residential, commercial and light industrial environment.

EN 61000-6-4, EN 61000-6-2. Industrial environment.

Turenki 09.03.2023



Jyrki Vesaluoma
Chairman of the board

Technical file collected by R&D manager

KOLMEKS OY
P.O.BOX 27 FI-14201 TURENKI, FINLAND
tel. +358 20 7521 31
www.kolmeks.com
export.finland@kolmeks.com

MINIMUM EFFICIENCY INDEX MEI

The efficiency of a pump with a trimmed impeller is usually lower than that of a pump with full impeller diameter. The trimming of the impeller will adapt the pump to a fixed duty point, leading to reduced energy consumption. The minimum efficiency index (MEI) is based on full impeller diameter.

The operation of this water pump with variable duty points may be more efficient and economic when controlled, for example, by the use of a variable speed drive that matches the pump duty to the system.

For pumps supplied after 1.1.2015 regulation 547/2012 is to be applied, Minimum Efficiency Index MEI > 0,4, benchmark for the most efficient water pumps is MEI > 0,7. Information on benchmark efficiency is available at: www.europump.org/efficiencycharts

8. Annex

8.1 Wiring diagram MDA-single pump

8.1.1 Wiring diagram MDA-single pump, 4 x Din

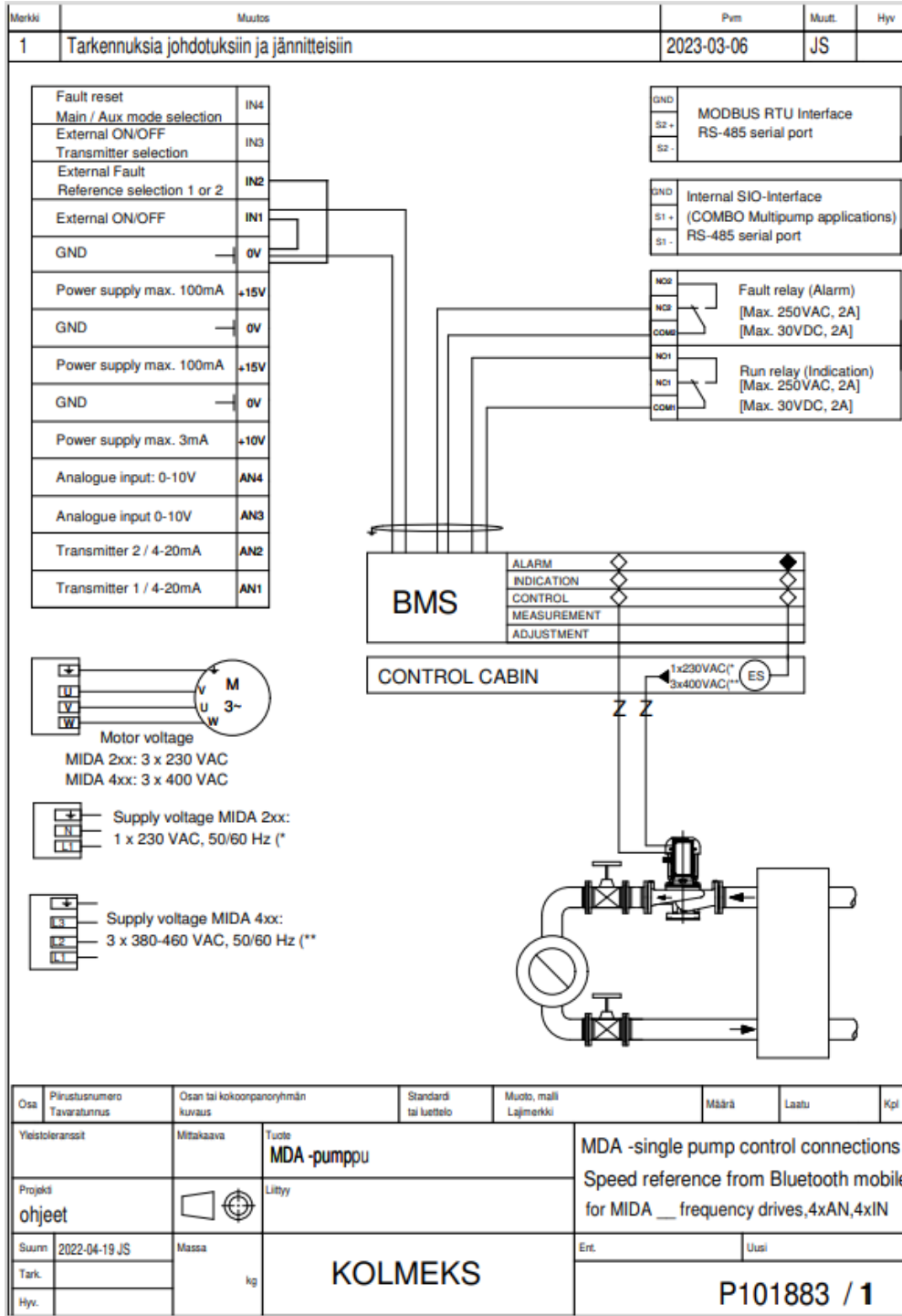

8.1.2 Wiring diagram MDA-single pump, 2 x Din

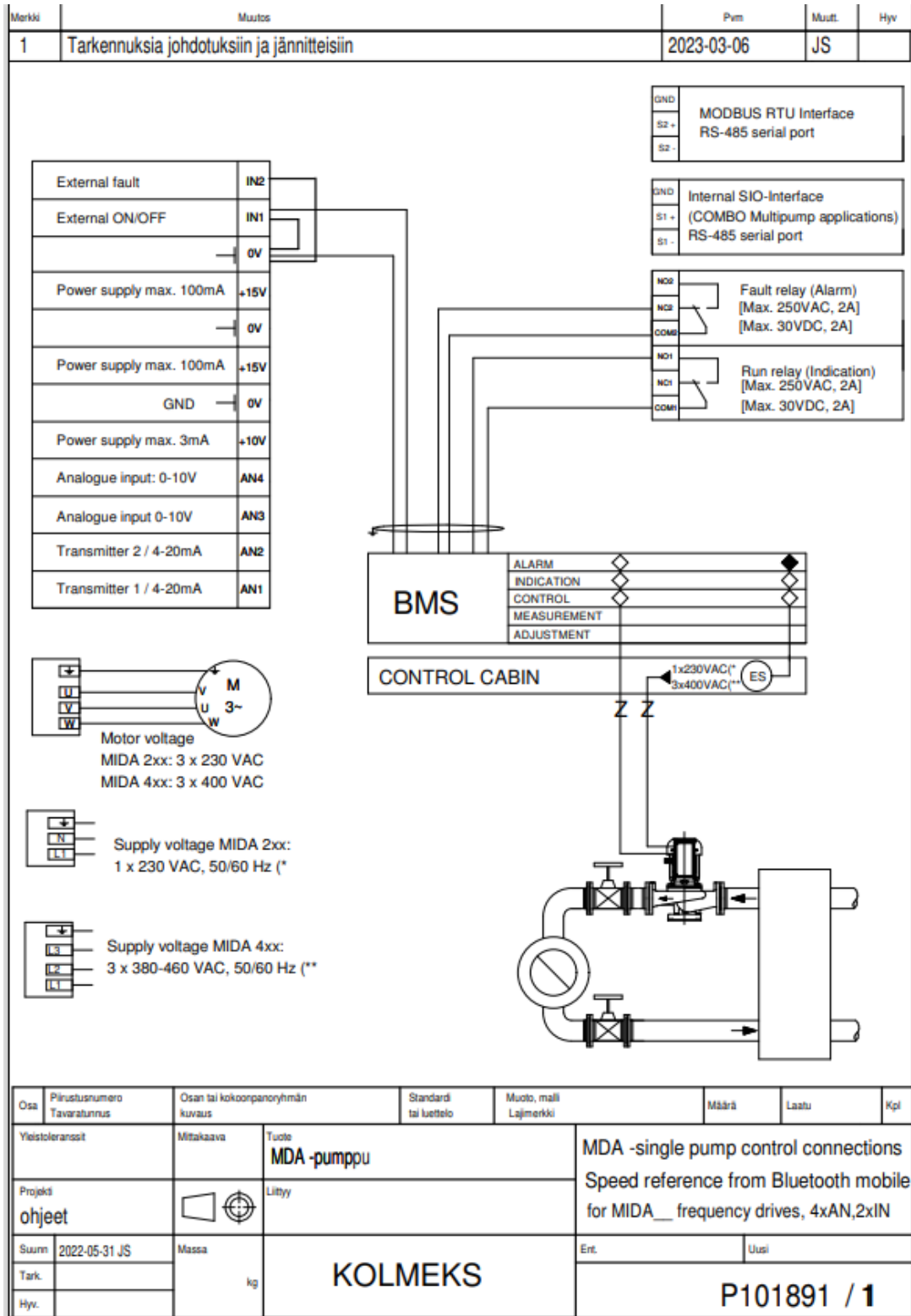

8.2 Wiring diagram MDB-single pump

8.2.1 Wiring diagram MDB-single pump, 4 x Din

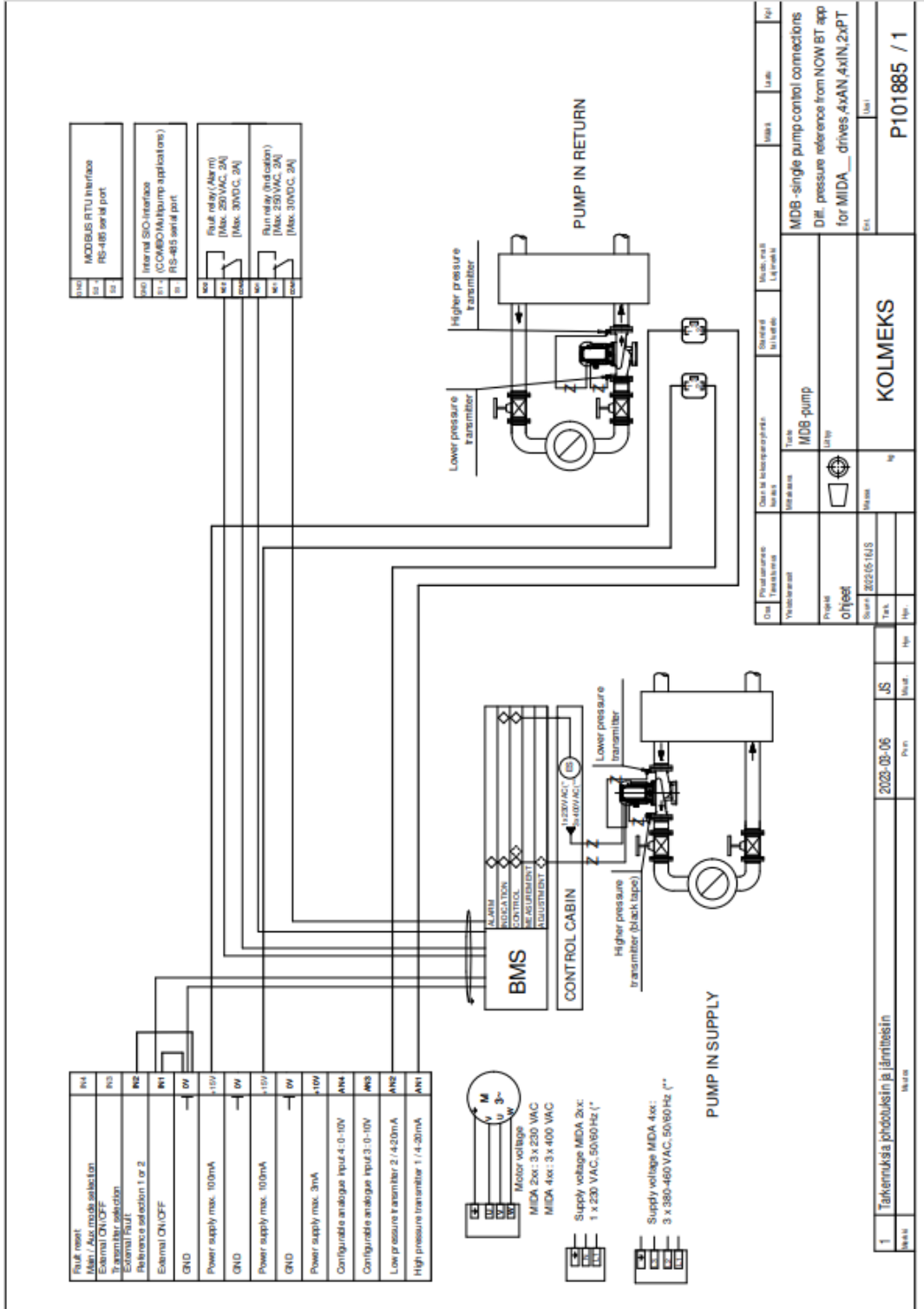

8.2.2 Wiring diagram MDB-single pump, 2 x Din

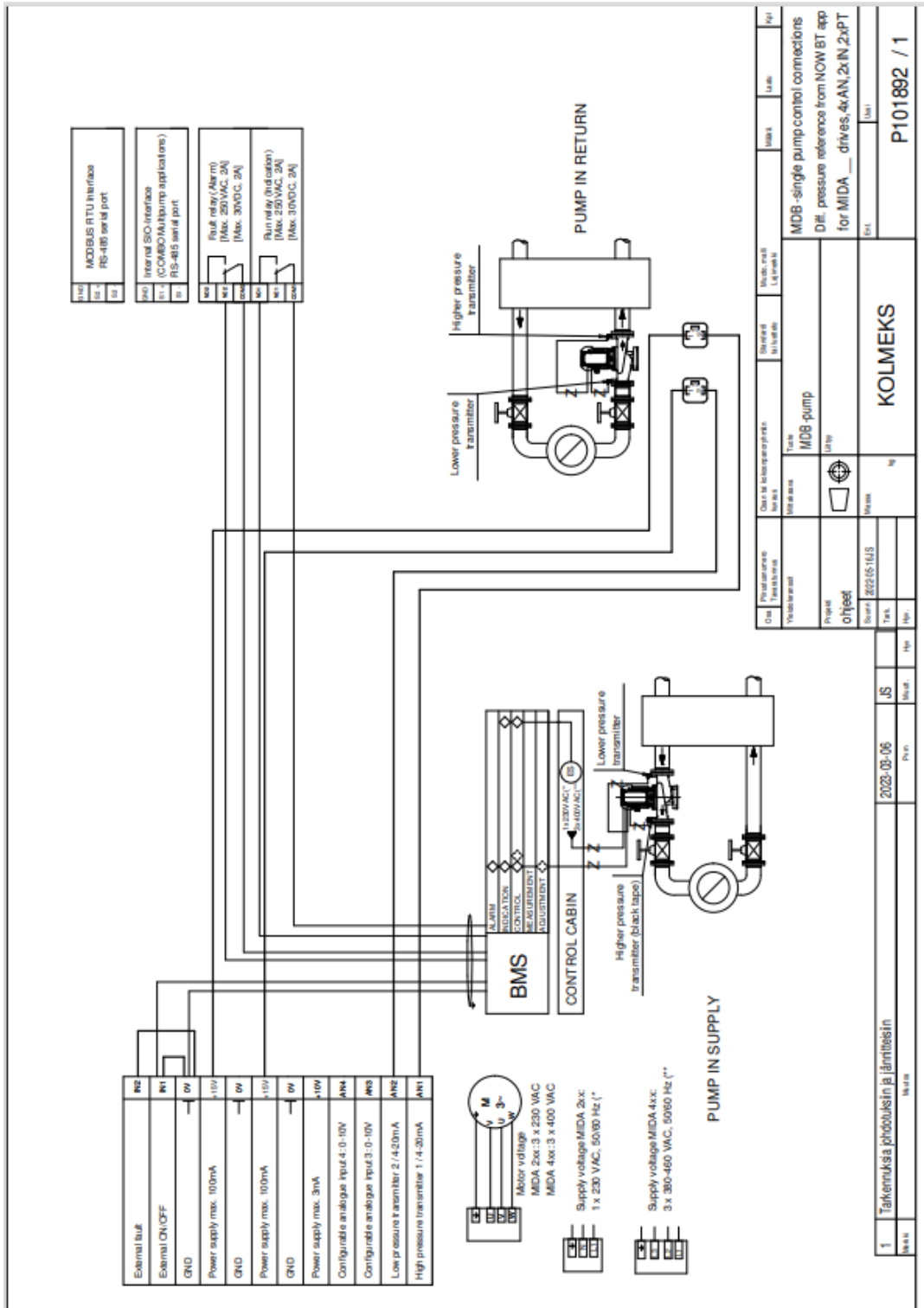

8.3 Wiring diagram MDC-single pump

8.3.1 Wiring diagram MDC-single pump, 4 x Din

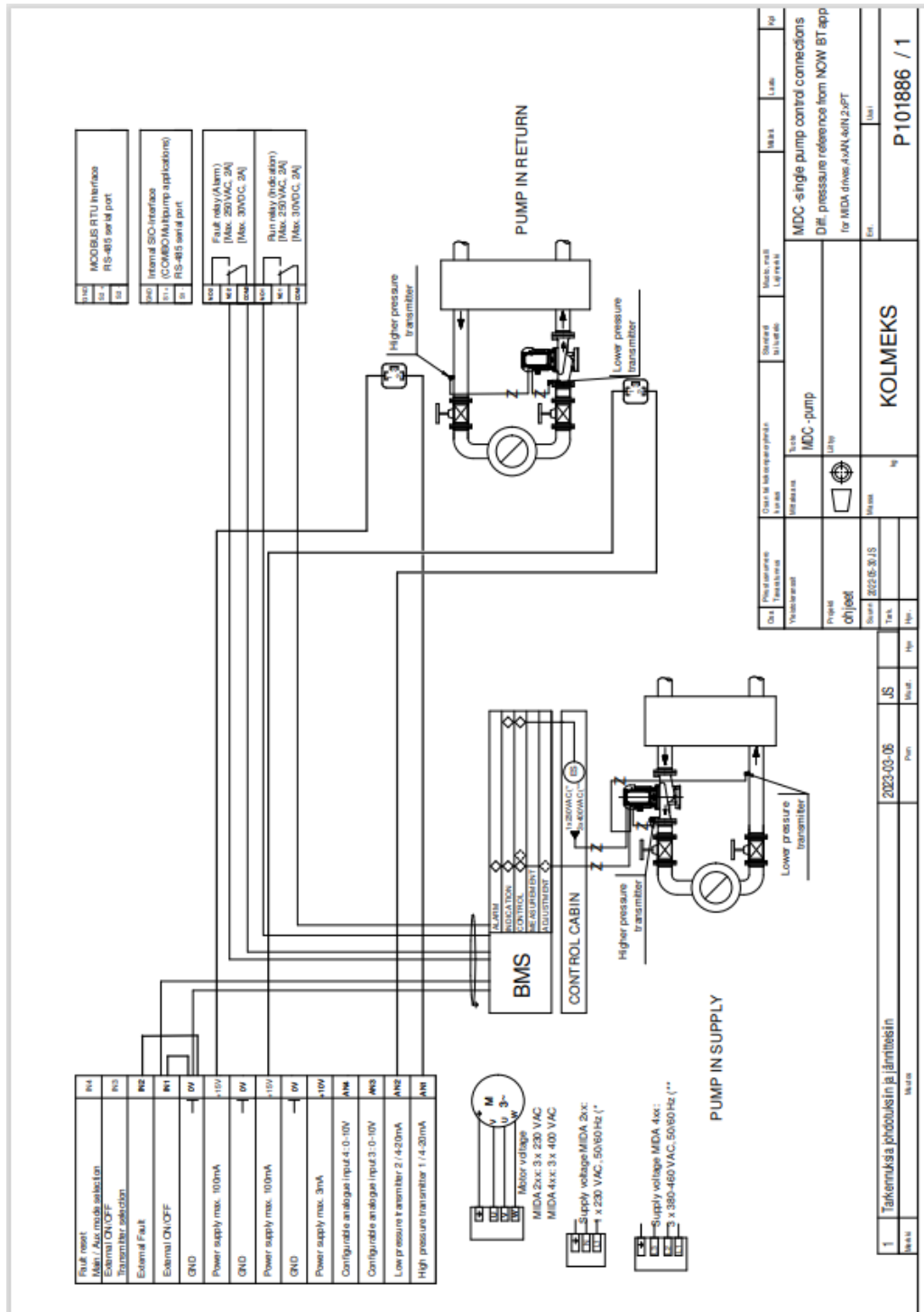

8.3.2 Wiring diagram MDC-single pump, 2 x Din

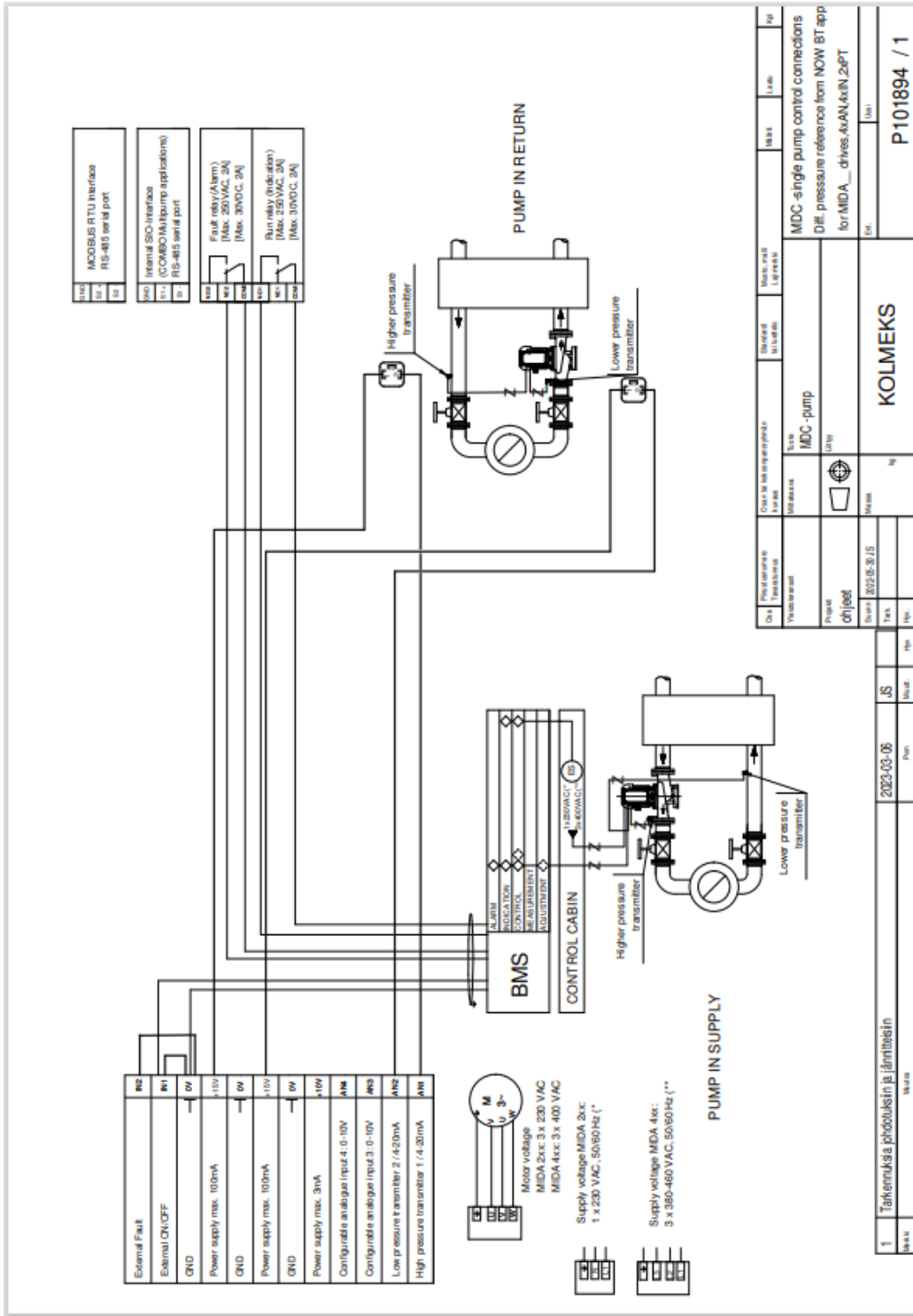

8.4 Wiring diagram MDD-single pump

8.4.1 Wiring diagram MDD-single pump, 4 x Din

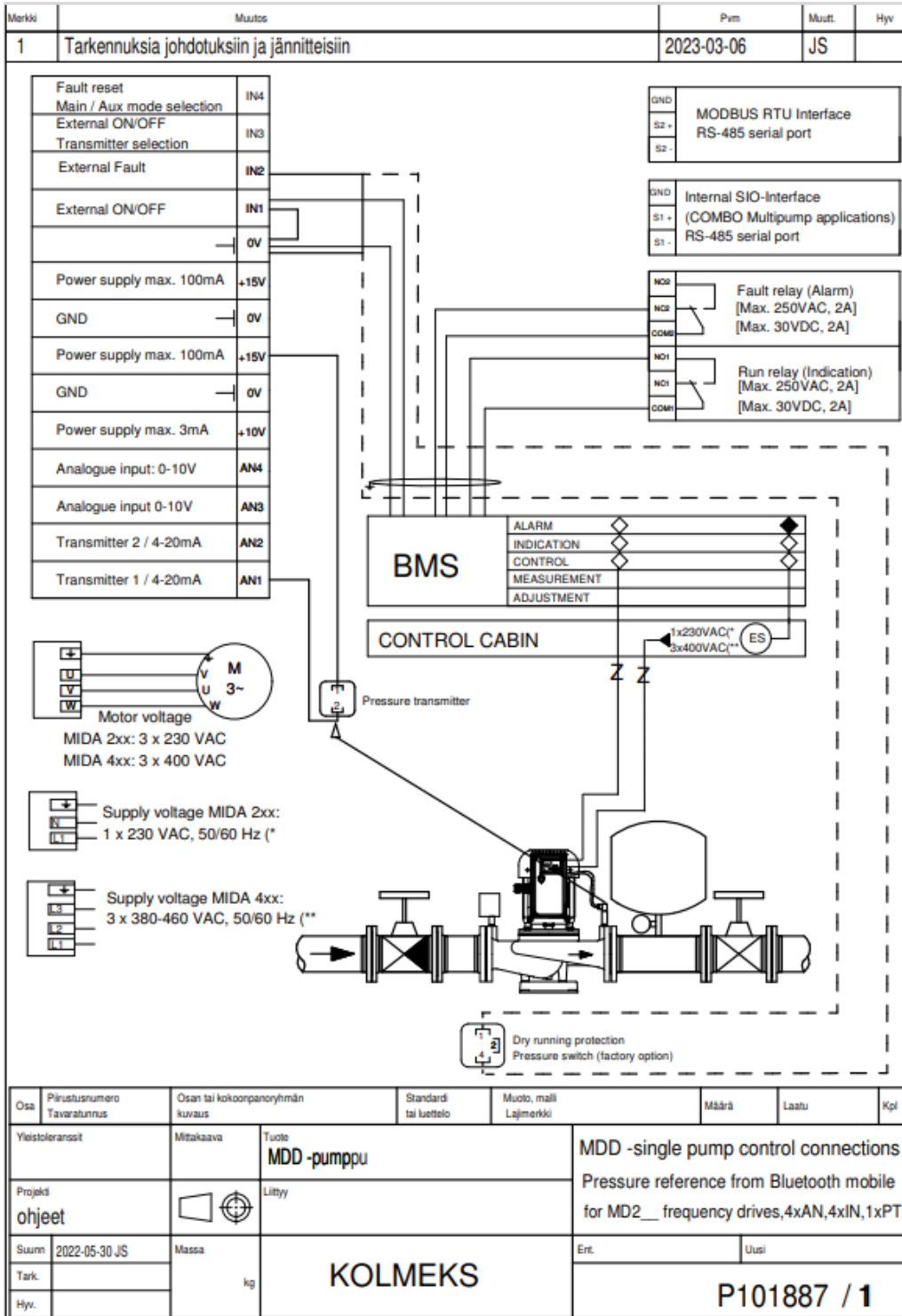

8.4.2 Wiring diagram MDD-single pump, 2 x Din

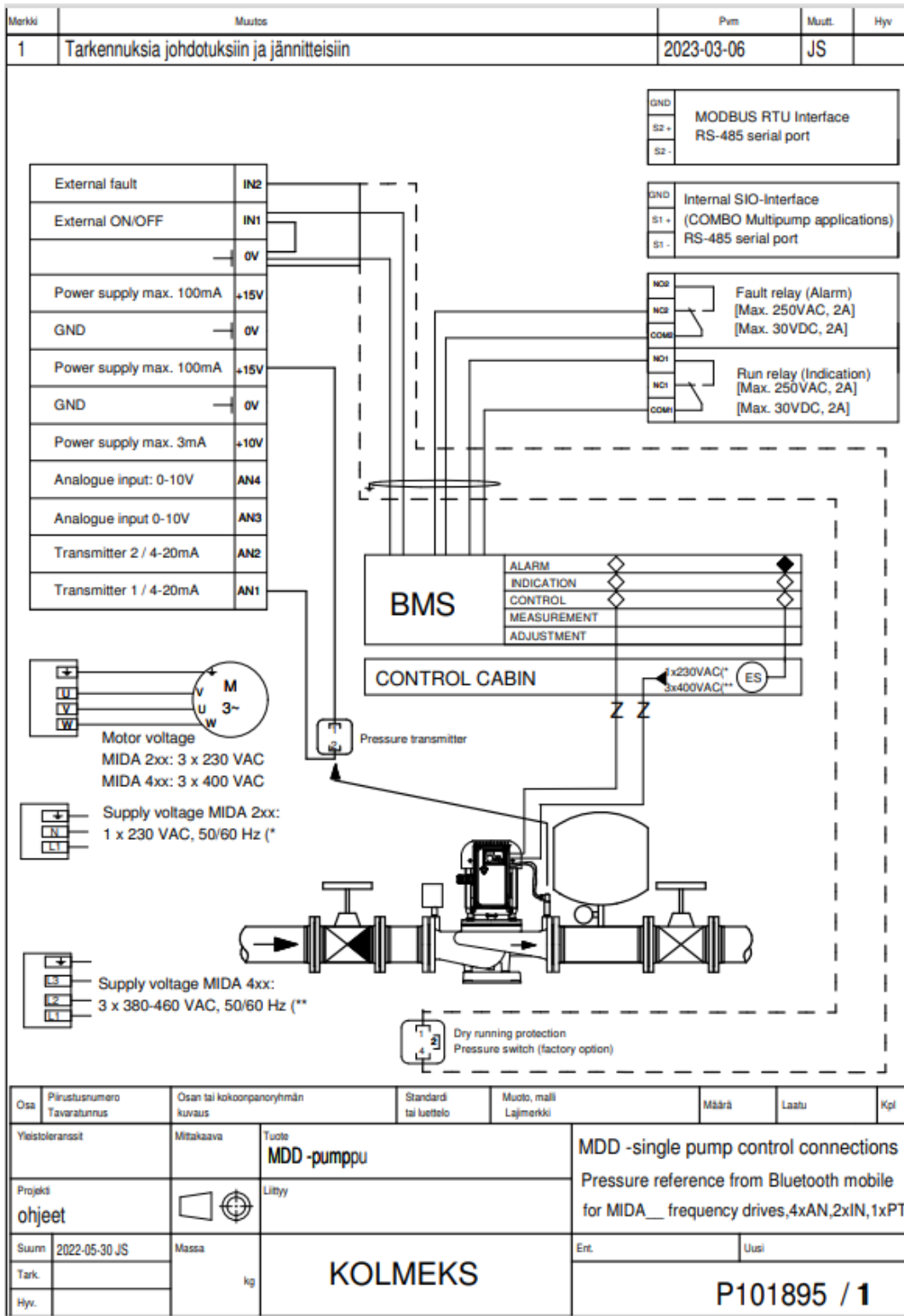

Osa	Piirustusnumero Tavaratunnus	Osan tai kokoonpanoryhmän kuvaus	Standardi tai luettelo	Muoto, malli Lajimerkki	Määrä	Laatu	Kpl
Yleistiedot		Mittakaava	Tuote MDD-pumppu	MDD -single pump control connections			
Projektin ohjeet		Lititty		Pressure reference from Bluetooth mobile for MIDA__ frequency drives,4xAN,2xIN,1xPT			
Suom.	2022-05-30 JS	Massa		Ent.		Uusi	
Tark.		kg	KOLMEKS				
Hyv.							P101895 / 1

8.5 Wiring diagram MDF-single pump

8.5.1 Wiring diagram MDF-single pump, 4 x Din

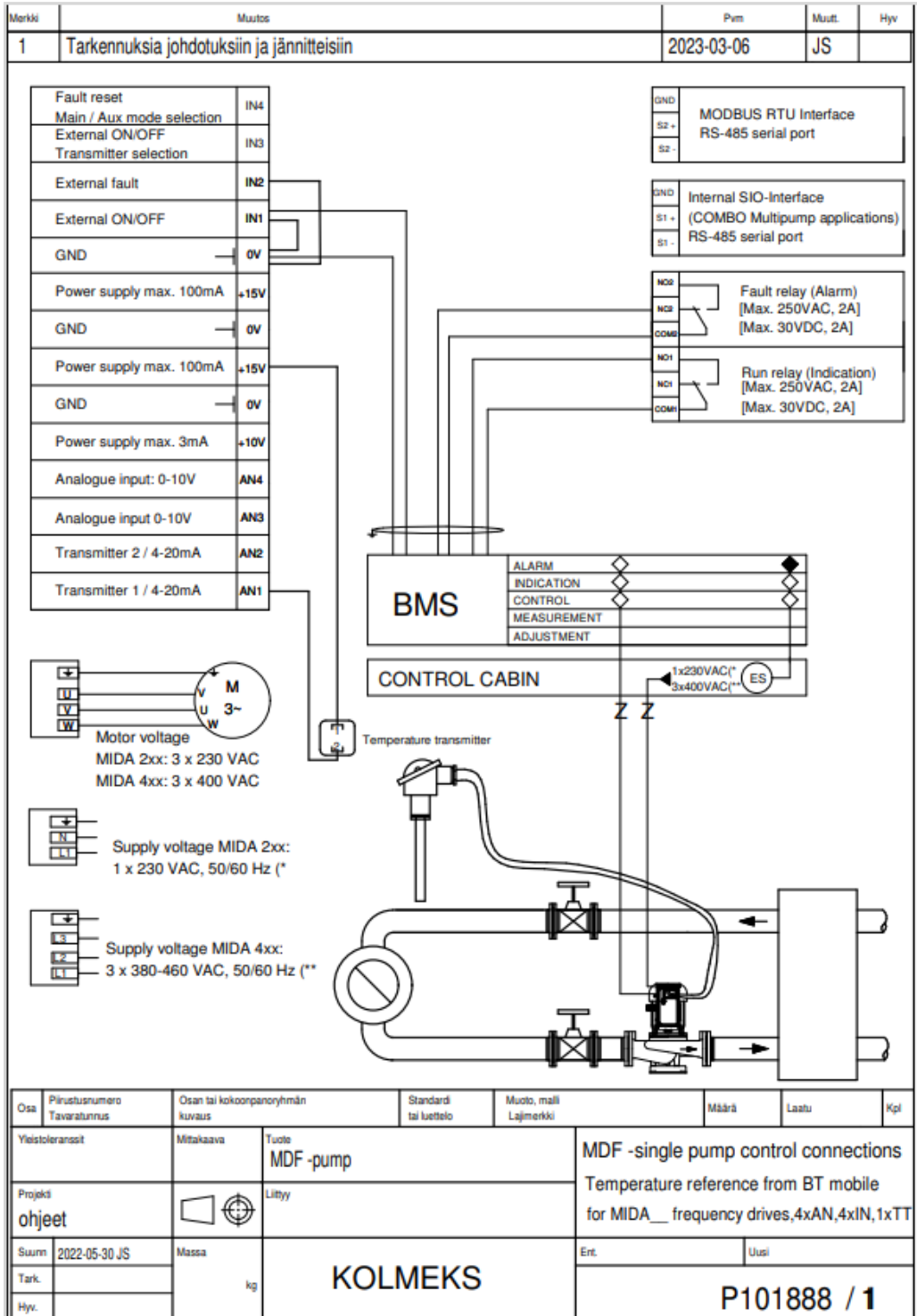

8.5.2 Wiring diagram MDF-single pump, 2 x Din

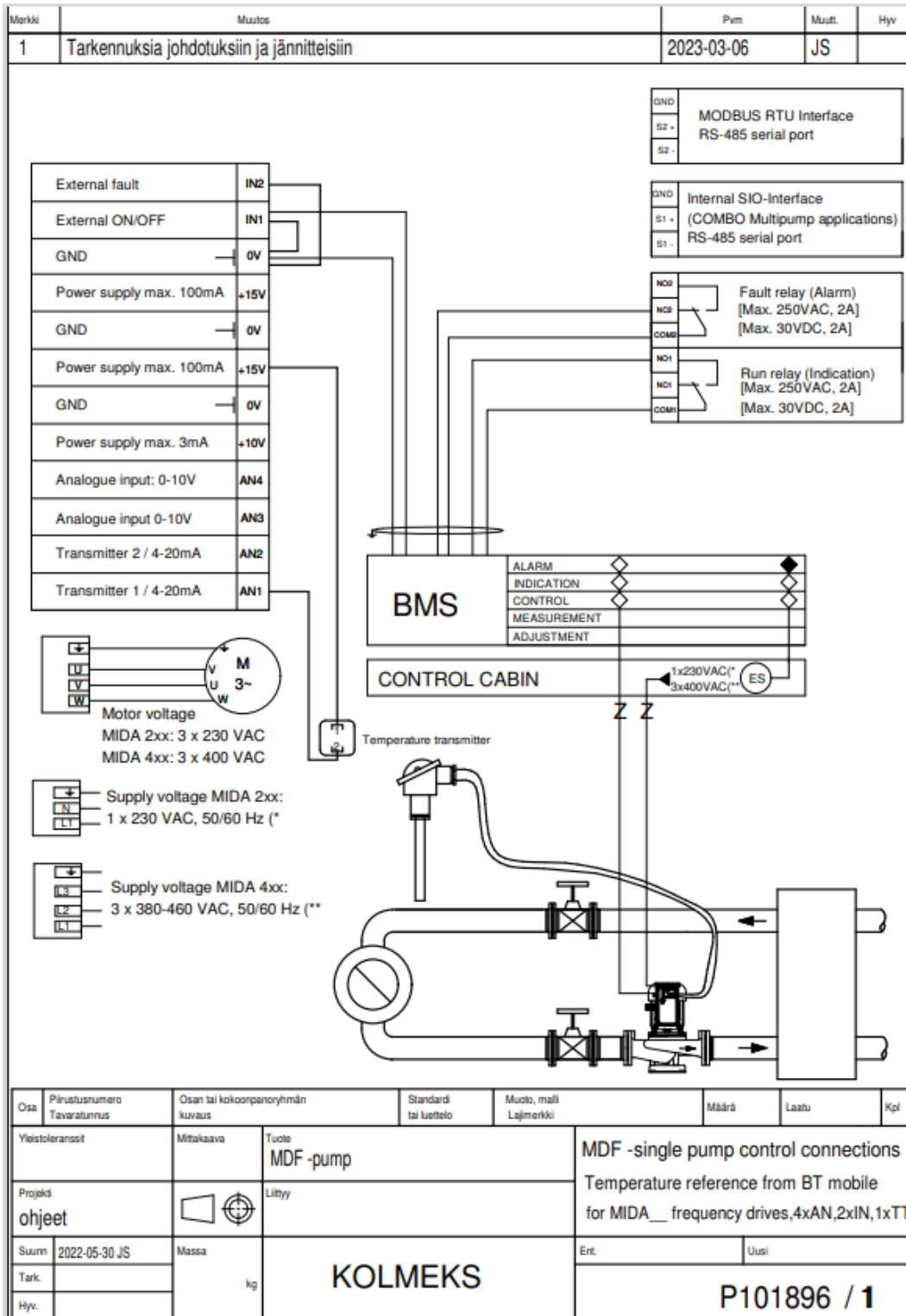

8.6 Wiring diagram MDG-single pump

8.6.1 Wiring diagram MDG-single pump, 4 x Din

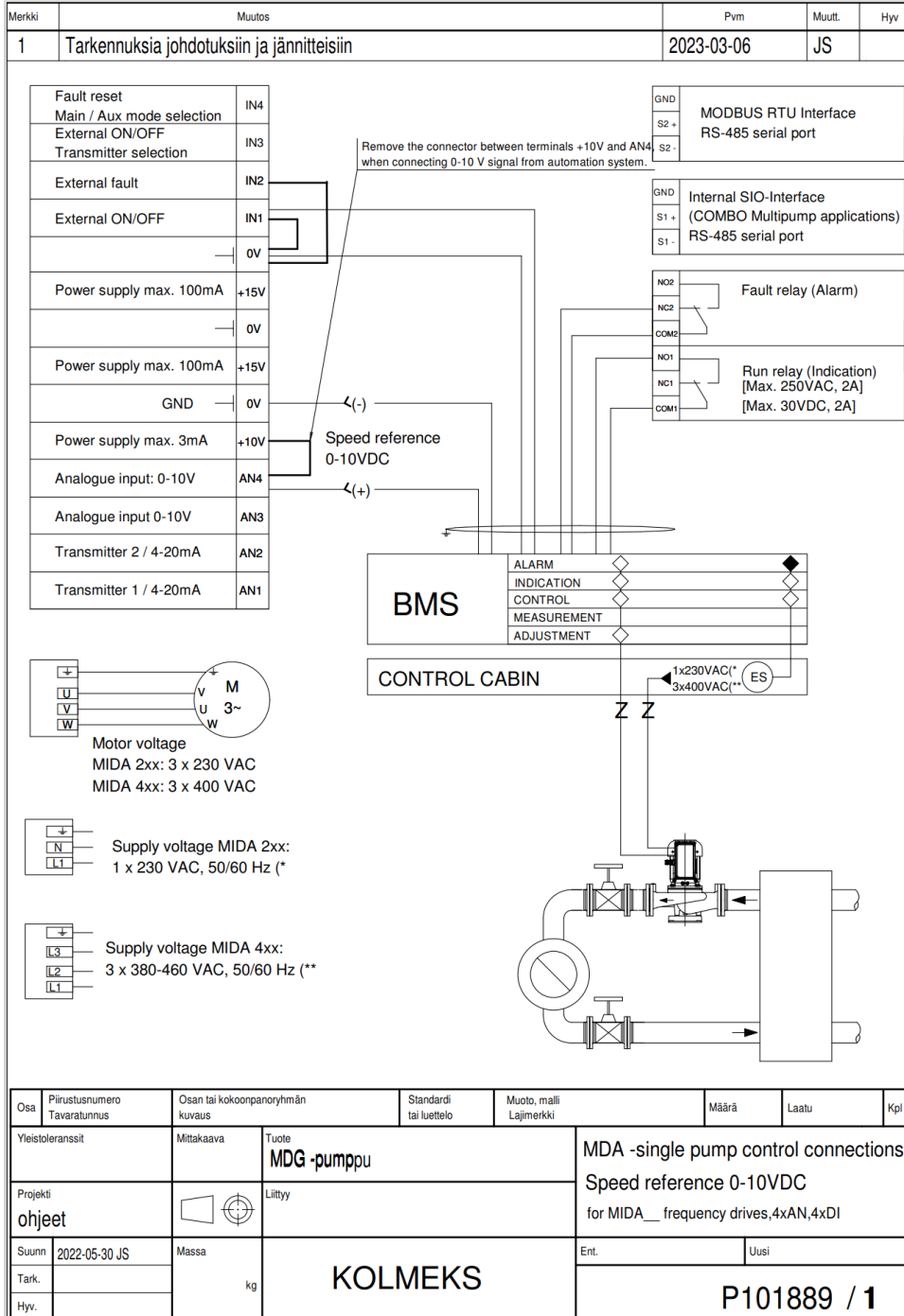

8.6.2 Wiring diagram MDG-single pump, 2 x Din

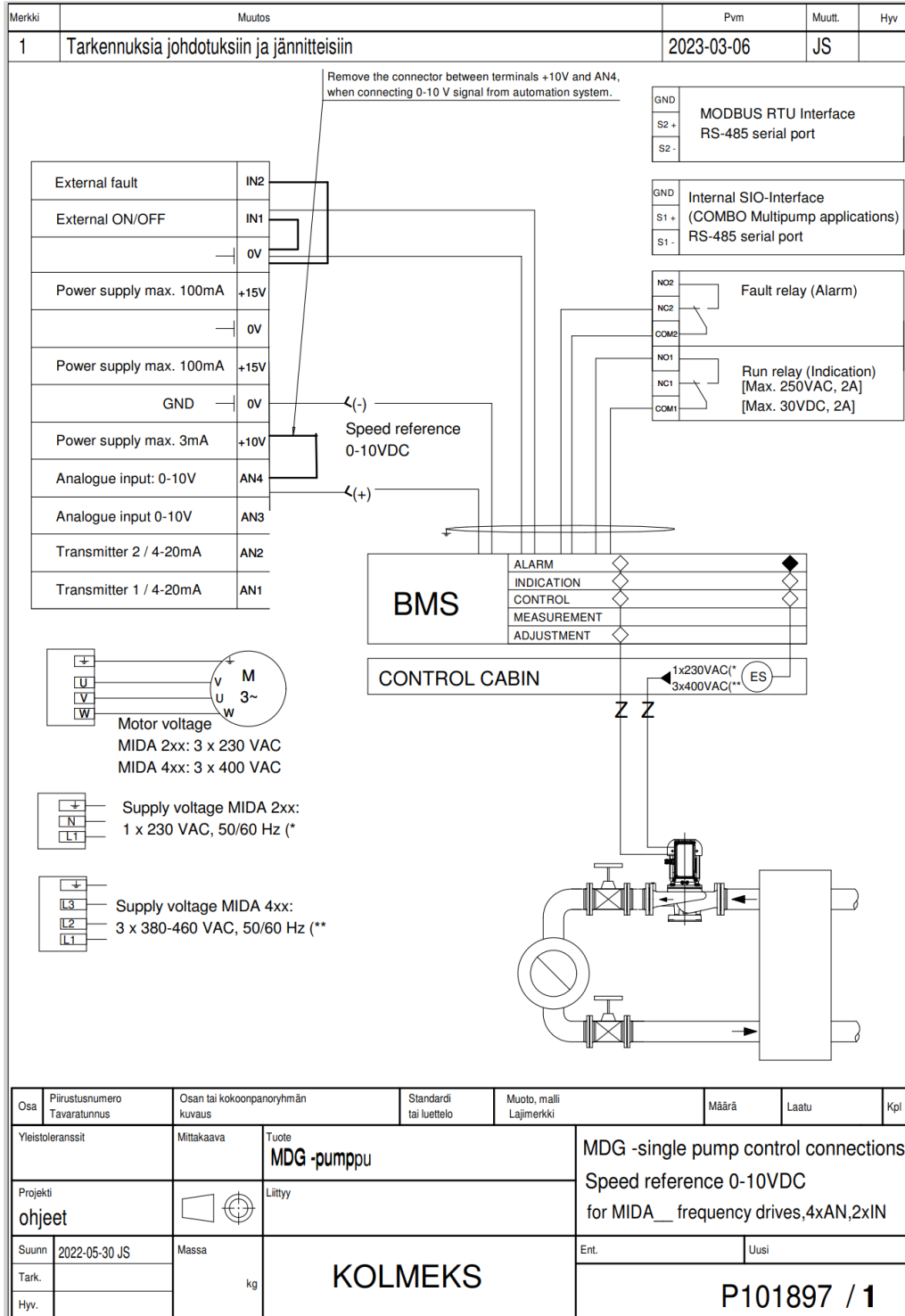

8.7 Wiring diagram MDM-single pump

8.7.1 Wiring diagram MDM-single pump, 4 x Din

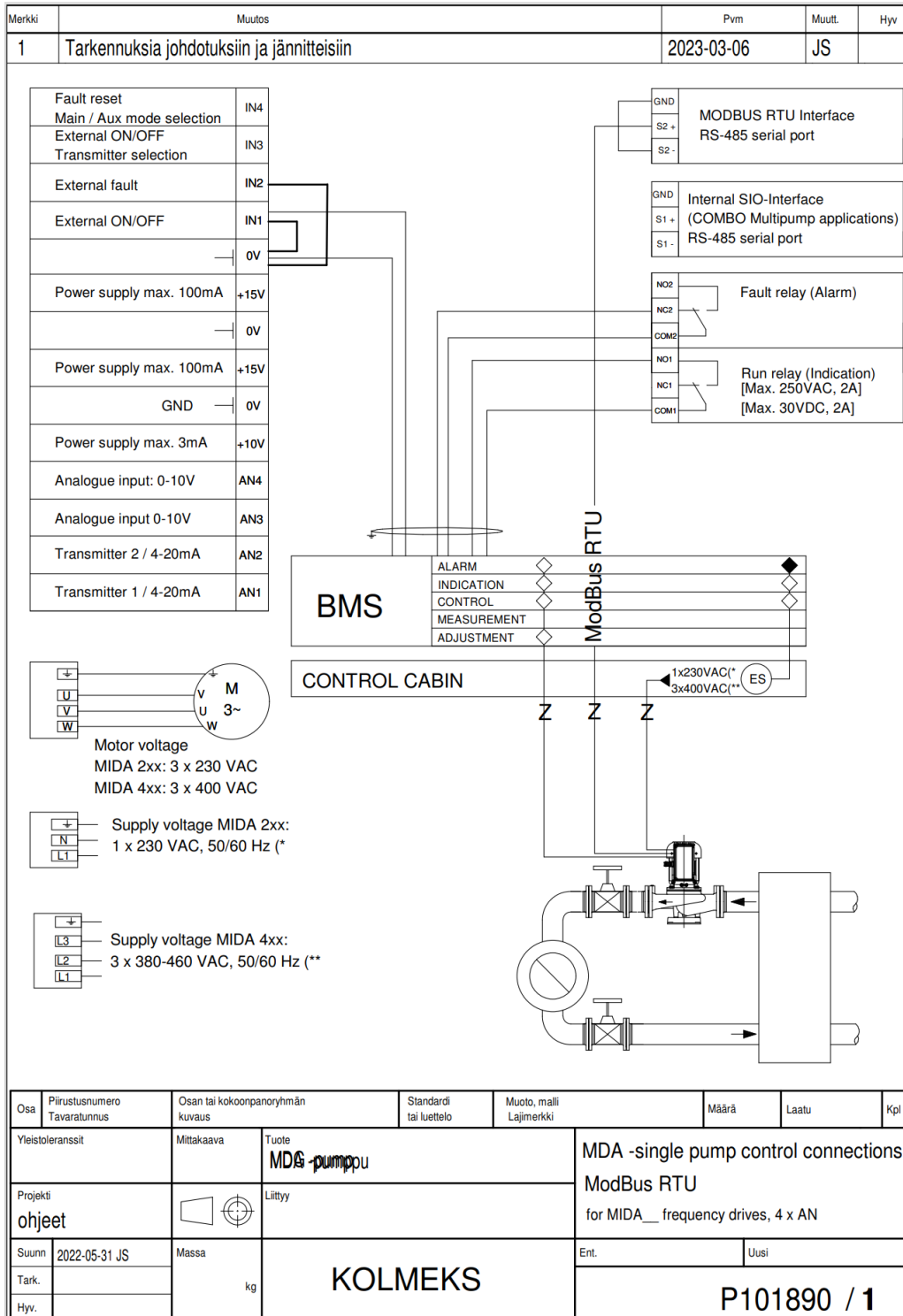

8.7.1 Wiring diagram MDm-single pump, 2 x Din

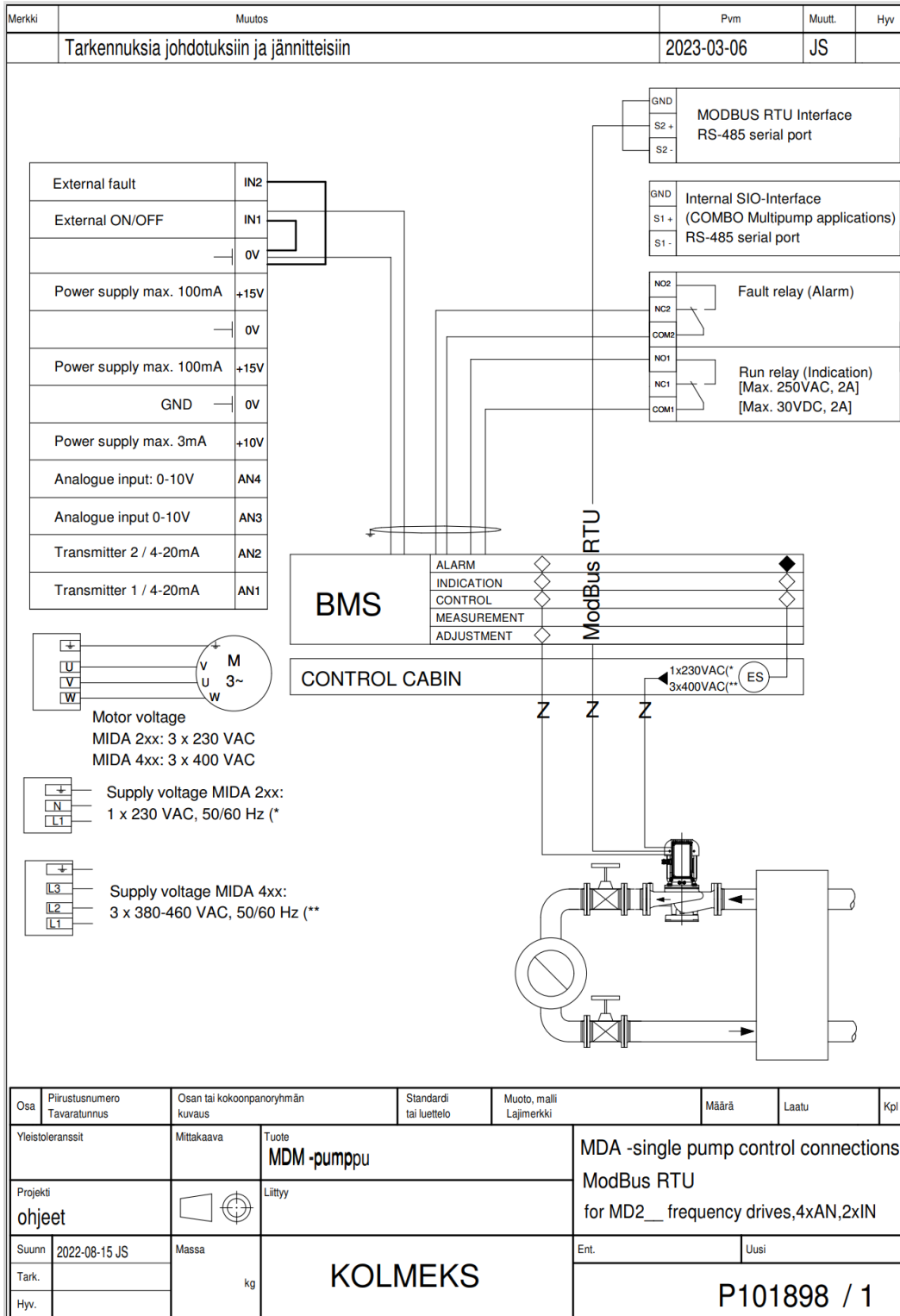

8.8 Nastec Now mobile application user guide

Kolmek's MD-pumps can be controlled with Nastec Now mobile application. Application can be downloaded from AppStore and from Google Play store free of charge by using QR-code below or in the first page of this manual. Mobile application is using Bluetooth connection.



Nastec NOW / AppStore



Nastec NOW / Google play

After downloading the application, it is recommended to register application user to ensure complete functionality of the application. Without registering user can execute basic operations, like monitoring and parametrizing.

8.8.1 Registering to Nastec Now user

After starting Nastec Now application, user is requested either to log in or. If you have registered or don't want to register, you can skip this chapter and move 8.8.2. If you haven't registered, choose `REGISTER`, feed your personal information and press again `REGISTER`. After this you will receive confirmation email. Please, check also your spam folder in case you don't receive email. Log in with used ID you just registered to see basic view of the application.

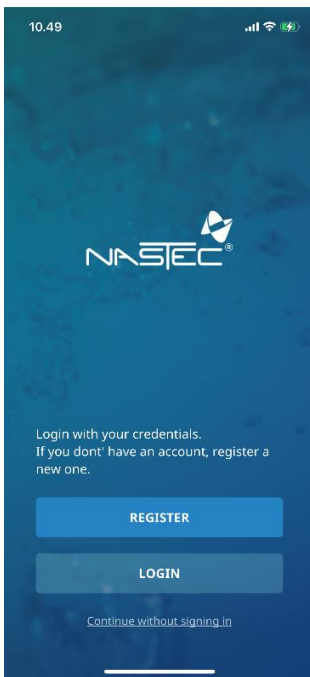

Start view

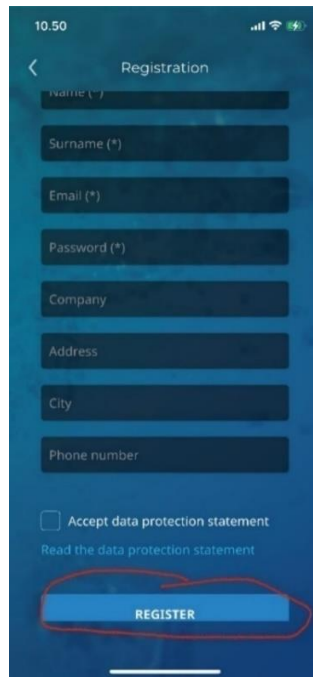

Register view

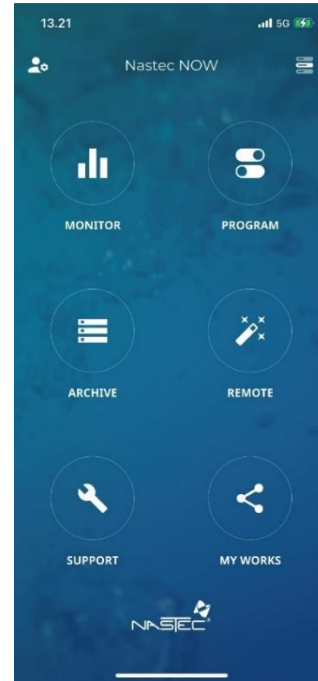

Application basic view

8.8.2 Connecting to device and changing the set value

When registering is completer or user doesn't want to register, the use of application can be started. Application opens to basic view, where should be selected `PROGRAM` by pressing the icon. When Nastec Now is not connected to any frequency converter, it opens search view, when user should press `SEARCH`. Application starts searching frequency converters close to user. Please note, that Bluetooth signal flows only some meters. Observed devices are indicated in device list with white color and connection strength is indicated next to the device ID. Press the device ID you want to connect. Finally, the application is asking passwords, which are PW1=001 and PW2=002. After confirming the passwords application moves to program menu.

When the application is connected, in green background states `Connected`.

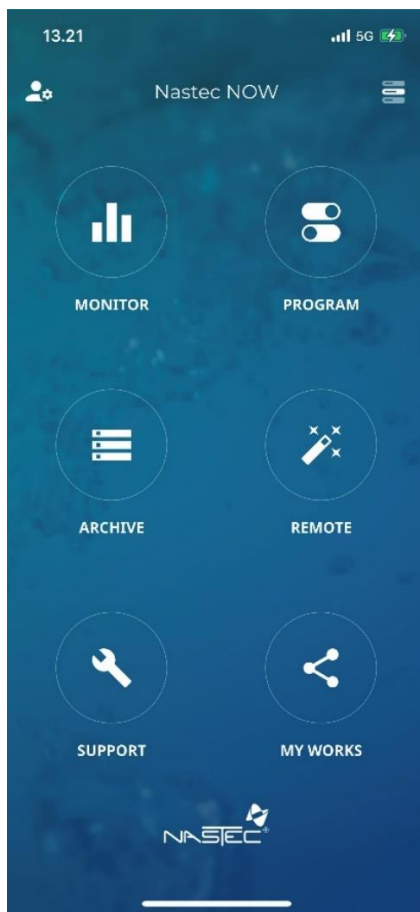

Application basic view



Search view

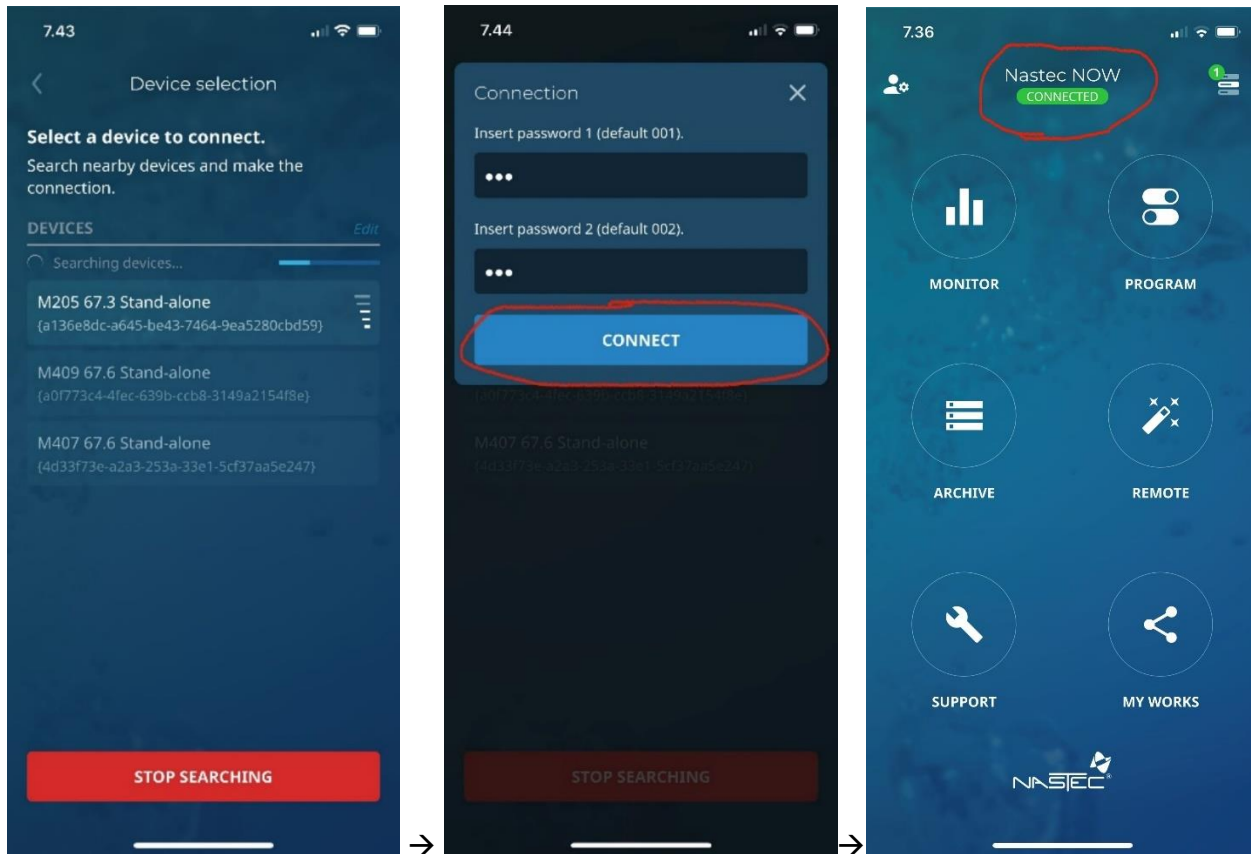

Application has found the drive

Connecting the devices

Application connected to the drive

8.8.3 Changing the set value

Set values are changed from NASTEC NOW application `PROGRAM`-menu `CONTROL`-tab. Depending on the operation mode of the pump `CONTROL`-tab looks slightly different. In case of direct frequency reference (MDA-version), should be chosen `Operating frequency [Hz]` by pressing the correct row. After this the application requests to write new frequency reference, which is confirmed by pressing `OK`. Changed value is indicated with yellow color, which means, that value is not written to the frequency converter so far. Changed values are saved to the frequency converter by pressing `WRITE`. Please note, that when writing values with mobile application, pump must be stopped. If the pump is running, application requests to stop the pump before writing the parameters. After writing the latest parameters, pump should be started from `MONITOR`-menu by pressing `START`.

If user wants to use PI-controller or automation system voltage signal instead of fixed speed, should operation mode be changed from `PROGRAM`-menu `CONTROL`-tab by choosing `Control mode`. If PI-controller is used, should be selected `Constant value`. If automation system voltage signal is used, should be selected `External speed`.

Pressure difference (MDB- and MDC-versions) or outlet pressure (MDD-version) set point is changed in corresponding way at `PROGRAM`-menu `CONTROL`-tab. Then should be changed parameter `Set value [m]`. New set value is written in similar way as in case of MDA-version fixed speed reference.

Fixed speed and PI-controller reference value is possible to change without stopping the pump. Please read 5.4 Control methods and choose the correct method for your pump.

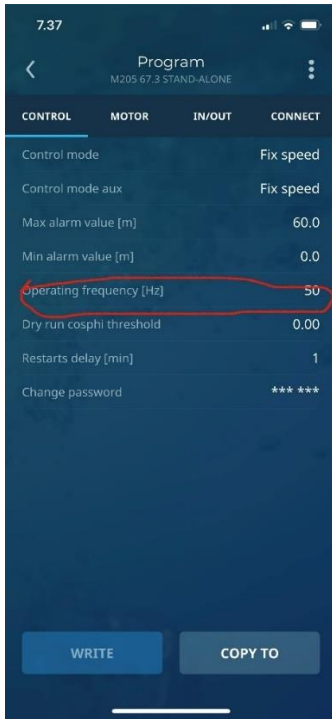

Program-menu

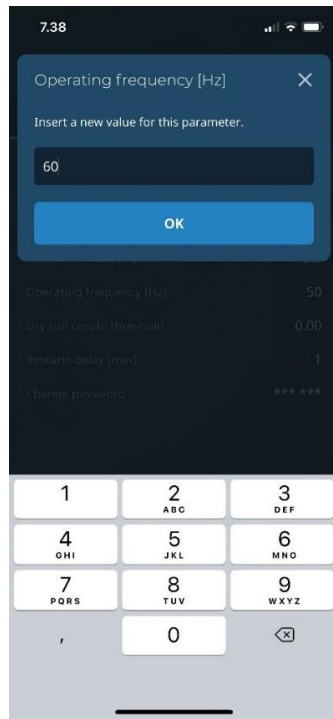

Placing new frequency reference



Saving the changed value

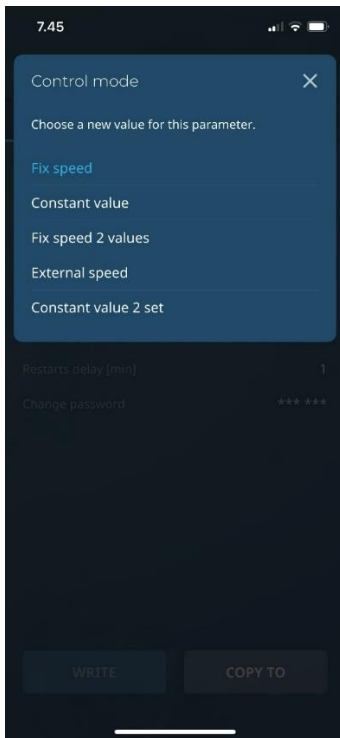

Changing the operation mode



Changing PI-controller set value

8.8.4 Pump and motor monitoring

Pump and motor conditions and active alarms can be monitored with mobile application. When pump is stopped from keypad or from application, in STATUS`-row is indicated `NORMAL OFF`. When pump is running, `STATUS` is `RUN`.

If automation system ON-command (IN1) is disconnected, in `STATUS`-row states `DIGITAL INPUT ACTIVE`. In addition, Monitor menu bottom is shown active warning `W01`.

When pressure transmitter(s) are connected to the pump, measured value is shown in `Actual value [m]` and set point in `Set value [m]`. If set point is indicated with three lines, operation mode doesn't notify measured value, but is operating according to other reference.

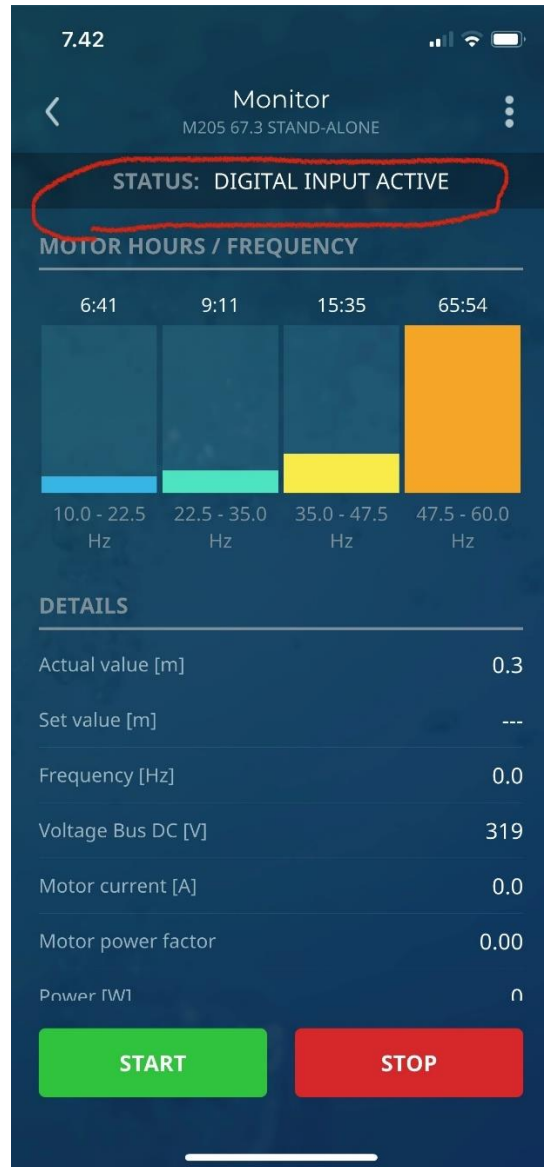
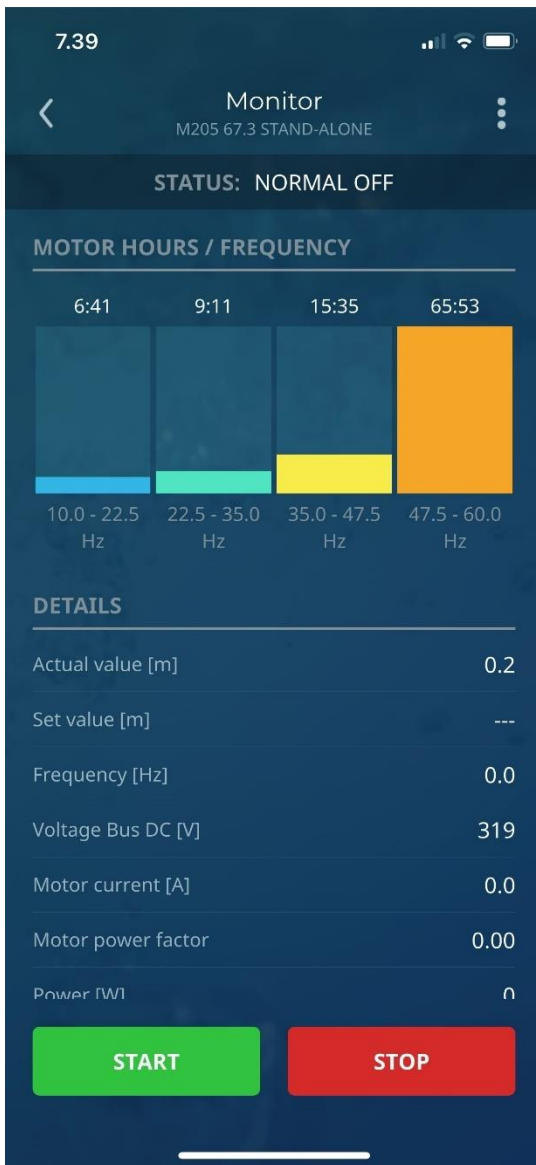

8.8.5 Remote use

MD-series pumps can be supervised and controlled with remote connection. To enable remote connection local user needs to be connected to the frequency converter with Bluetooth application. Local user should head to `REMOTE`-menu and choose either `Smart bridge` (remote user with mobile device) or `REMO` (remote user with PC).

When connecting with Smart bridge remote user need 9-digit ID to open the connection. This ID is device specific and should not be shared publicly. As local user tells the ID for remote user either in phone or with message after you have formed connection to the controlled device. Remote user writes your ID to his/her device and requests to open remote connection. Local user needs to approve remote connection. Remote connection requires internet connection from local user.

With Remo press `START REMO`, choose connected device, connect mobile application to controlled device and tell remote user the device name (e.g. M205 67.3). Approve REMO, when remote user requests so.

NOTE! Local user needs to be connected and in proximity of controlled device during the remote control.

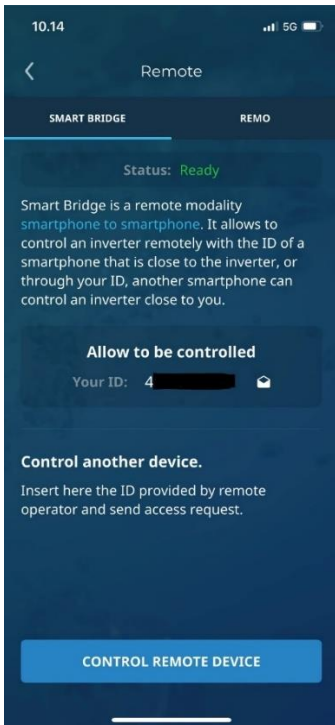

Smart bridge start view

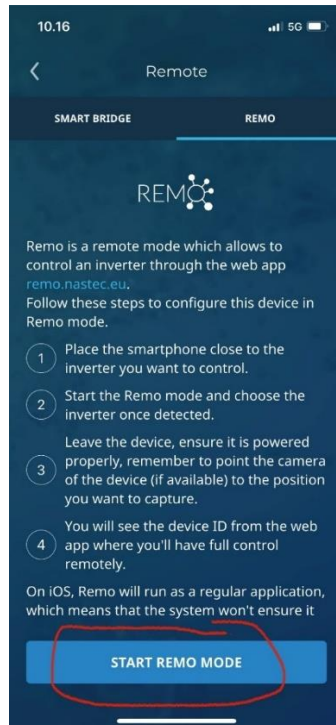

REMO start view