

# INSTALLATION AND OPERATING INSTRUCTIONS CENTRIFUGAL PUMPS WITH INTEGRATED FREQUENCY DRIVE MD-SERIES

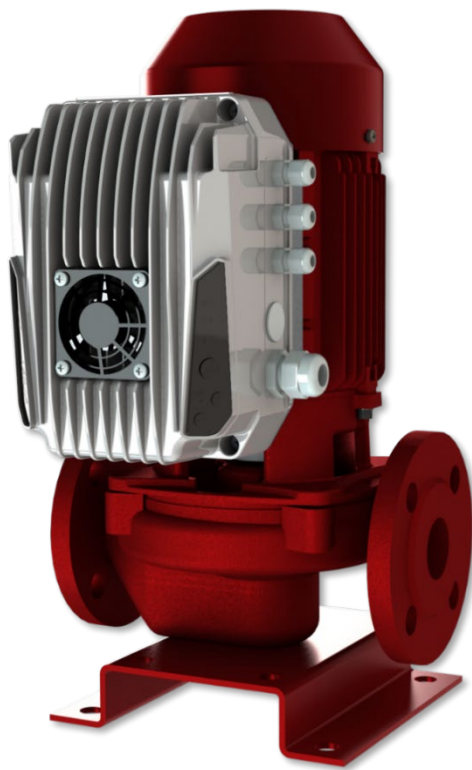

Nastec NOW / AppStore



Nastec NOW / Google play

## Contents

1. General.....	5
1.1 Symbols .....	5
1.2 Fields of applications.....	5
1.2.1 AE_-, L_-, AL_- pumps.....	5
1.2.2 AEP-, LP-, ALP- pumps .....	5
1.2.3 LH-, ALH- pumps .....	5
1.2.4 LS-, ALS- pumps.....	5
1.3 Limits of application and use .....	6
1.4 Manufacturer .....	6
1.5 Version .....	6
2. Handling, transport and storage of the pump .....	6
3. Design and function .....	7
3.1 Construction .....	7
3.2 Technical data .....	7
3.2.2 Connecting the supply voltage for frequency converter .....	9
3.3 Pump identification .....	12
4. Safety .....	13
4.1 Safety instructions .....	14
4.2 Training .....	14
4.3 Elements of danger if safety regulations are not obeyed.....	14
4.4 Safety instructions for inspection and assembly .....	14
4.5 Operating the pump.....	14
5. Installation, introduction and start-up.....	14
5.1 Positions for installation .....	15
5.2 Electrical connections.....	15
5.2.1 Low voltage connections.....	15
5.2.2 Safety extra low voltage (SELV) connections.....	16
.....	16
5.3 Using MD-pump with Nastec Now mobile application or locally from keypad.....	17
5.4 Regular rotation of the pump .....	17
5.5 Control methods .....	18
5.5.1 MDA-pump – Frequency reference for frequency converter .....	18

5.5.2	MDB- pump – constant pressure between the pump flanges .....	19
5.5.3	MDC- pump - constant pressure in between inlet- and outlet-line.....	20
5.5.4	MDD- pump - constant pressure in discharge (pressure boosting) .....	21
5.5.5	MDF- pump - constant temperature .....	22
5.5.6	MDG- pump - controlled by external system.....	22
6.	Service, spare parts and troubleshooting .....	23
6.1	Shaft seals.....	23
6.2	Other parts .....	24
6.3	Troubleshooting.....	25
8.	Annex .....	34
8.1	Wiring diagram MDA-single pump.....	34
8.1.1	Wiring diagram MDA-single pump, 4 x Din.....	34
8.1.2	Wiring diagram MDA-single pump, 2 x Din.....	35
8.2	Wiring diagram MDB-single pump .....	36
8.2.1	Wiring diagram MDB-single pump, 4 x Din.....	36
8.2.2	Wiring diagram MDB-single pump, 2 x Din.....	37
8.3	Wiring diagram MDC-single pump.....	38
8.3.1	Wiring diagram MDC-single pump, 4 x Din.....	38
8.3.2	Wiring diagram MDC-single pump, 2 x Din.....	39
8.4	Wiring diagram MDD-single pump .....	40
8.4.1	Wiring diagram MDD-single pump, 4 x Din.....	40
8.4.2	Wiring diagram MDD-single pump, 2 x Din.....	41
8.5	Wiring diagram MDF-single pump .....	42
8.5.1	Wiring diagram MDF-single pump, 4 x Din .....	42
8.5.2	Wiring diagram MDF-single pump, 2 x Din .....	43
8.6	Wiring diagram MDG-single pump.....	44
8.6.1	Wiring diagram MDG-single pump, 4 x Din .....	44
8.6.2	Wiring diagram MDG-single pump, 2 x Din .....	45
8.7	Wiring diagram MDM-single pump.....	46
8.7.1	Wiring diagram MDM-single pump, 4 x Din .....	46
8.8	Nastec Now mobile application user guide .....	48
8.8.1	Registering to Nastec Now user.....	48
8.8.2	Connecting to device and changing the set value .....	49

8.8.3 Changing the set value .....	50
8.8.4 Pump and motor monitoring .....	52
8.8.5 Remote use .....	53

## 1. General

### 1.1 Symbols



Warns that failure to observe the precaution may cause personal injury or damage to property.



Warns that failure to observe the precaution may cause electric shock.

ATTN!

Indicates something to be noted by the reader

### 1.2 Fields of applications

The most common applications are heating, air condition, cooling systems. Also heat exchangers, pressure boosting systems, district heating systems, ice halls, public baths and industrial processes.

#### 1.2.1 AE\_-, L\_-, AL\_- pumps

Clean, thin, non-aggressive liquids.

- circulating water in for heating and cooling systems
- water-glycol mixtures

#### 1.2.2 AEP-, LP-, ALP- pumps

Clean, thin, slightly aggressive liquids.

- domestic hot water, oxygen rich waters, sea water, etc.

#### 1.2.3 LH-, ALH- pumps

- as in L- and AL -series, but nominal pressure 16 bar

#### 1.2.4 LS-, ALS- pumps

Aggressive, thin, not bigger solid particles containing liquids

- in addition to above mentioned liquids various acids, salts, oxidizing and chemically active organic fluids

### 1.3 Limits of application and use

Nominal pressure:           AE-, AEP-, L-, AL-, ALP- pumps: 10 bar  
                                  LH-, ALH-, LS- and ALS-pumps: 16 bar

ATTN!



Medium temperature range: -10 ... + 90 °C

Ambient temperature: 0 ... +40°C

Suitability of materials and seals for pumped liquid shall be always checked between the purchaser and supplier. The nominal pressure and the max. temperature of pumped liquid are stamped on the pump rating plate. Never use the pump in any other application or conditions without manufacturer's acceptance. In the case of damage there may be danger to persons by having poisoning, burns, wounds etc. depending on the pumped liquid and its temperature and pressure. The pump surface temperature may cause danger depending on the working conditions.

### 1.4 Manufacturer

This product is manufactured by KOLMEKS OY, P.O.BOX 27, FIN-14201 TURENKI, FINLAND.

### 1.5 Version

Release date of this manual is 17.12.2024 This is version no. 7.

## 2. Handling, transport and storage of the pump

ATTN!

Normally the pumps are stable when they are transported and don't go down even, they are bent 10°. Pumps shall be stored in a dry and cool place protected from dust. Temperature of environment must be in -10 °C ... +50°C. It is not allowed to lift the pump from frequency converter. In the case of longer storage time or the pump serves as a stand-by, it is recommended to rotate the pump manually eg. from the motor fan at least once a month.

### 3. Design and function

#### 3.1 Construction

The pump and motor constitute a unit, where the rotating parts of both the pump and the motor are on the same

shaft (mono-block design). The motor is of a dry type and the frequency converter is integrated to the electric motor.

Electric motor: Totally enclosed, fan cooled A.C. motor, with frequency converter.

Protection form: IP54 / IP55

Insulating class: F

#### 3.2 Technical data

##### MD-pumps, variable speed drive unit with 1 X 230 V supply voltage

Pump type	Connection	Nominal power P <sub>2n</sub> kW	Grid frequency Hz	Input current A max 1 x 230 V <sup>1)</sup>	Circuit breaker A <sup>2)</sup>	Supply cable[mm <sup>2</sup> ] max. length 20m <sup>3)</sup>	Weight kg	dB(A) 1m
AE-26/2 MD	R 1"	1,1	50 - 60	8	10	2 x 2.5 + 2.5	22	55
AE-33/2 MD	R 1 1/4"	1,1	50 - 60	8	10	2 x 2.5 + 2.5	30	55
AE-33/2 MD	R 1 1/4"	1,5	50 - 60	11	16	2 x 2.5 + 2.5	38	60
L-32A/2 MD	DN 32	1,1	50 - 60	8	10	2 x 2.5 + 2.5	29	55
L-40A/2 MD	DN 40	1,1	50 - 60	8	10	2 x 2.5 + 2.5	30	55
L-40A/2 MD	DN 40	1,5	50 - 60	11	16	2 x 2.5 + 2.5	43	60
L-50A/4 MD	DN 50	0,75	50 - 60	6	10	2 x 2.5 + 2.5	37	52
L-50B/2 MD	DN 50	1,1	50 - 60	8	10	2 x 2.5 + 2.5	37	55
L-50D/2 MD	DN 50	1,5	50 - 60	11	16	2 x 2.5 + 2.5	45	60
L-65A/4 MD	DN 65	0,75	50 - 60	8	10	2 x 2.5 + 2.5	53	52
L-65A/4 MD	DN 65	1,5	50 - 60	11	16	2 x 2.5 + 2.5	57	53
L-80A/4 MD	DN 80	0,75	50 - 60	8	10	2 x 2.5 + 2.5	59	52
L-80A/4 MD	DN 80	1,5	50 - 60	11	16	2 x 2.5 + 2.5	63	53
AL-1102/4 MD	DN 100	0,75	50 - 60	8	10	2 x 2.5 + 2.5	74	55
AL-1102/4 MD	DN 100	1,5	50 - 60	11	16	2 x 2.5 + 2.5	77	55

1) Allowed fluctuation for supply voltage +/- 15%

2) The fuse must be of type gG and the circuit breaker must follow the C or D curve

3) Longer cables should be dimensioned to consider local conditions and installation regulations.

**MD-pumps, variable speed drive unit with 3 X 380-460 V supply voltage**

Pump type	Connection	Nominal power	Grid frequency	Input current A max	Circuit breaker	Supply cable [mm <sup>2</sup> ]	Weight	dB(A)
		P <sub>2n</sub> kW	Hz	3 x 380-460 V <sup>1)</sup>	A <sup>2)</sup>	max. length 20m <sup>3)</sup>		
L-50D/2 MD	DN 50	3	50 - 60	7	16	3 x 2.5 + 2.5	54	65
L-65A/4 MD	DN 65	2,2	50 - 60	7	16	3 x 1.5 + 1.5	63	55
L-65B/2 MD	DN 65	3	50 - 60	7	16	3 x 2.5 + 2.5	63	65
L-65B/2 MD	DN 65	4	50 - 60	8	16	3 x 2.5 + 2.5	67	65
L-65B/2 MD	DN 65	7,5	50 - 60	14	25	3 x 6 + 6	102	74
L-80A/4 MD	DN 80	3	50 - 60	7	16	3 x 2.5 + 2.5	69	65
L-80A/2 MD	DN 80	3	50 - 60	7	16	3 x 2.5 + 2.5	69	65
L-80A/2 MD	DN 80	4	50 - 60	8	16	3 x 2.5 + 2.5	73	65
L-80A/2 MD	DN 80	7,5	50 - 60	14	25	3 x 6 + 6	107	74
AL-1102/4 MD	DN 100	3	50 - 60	7	16	3 x 2.5 + 2.5	77	56
AL-1102/2 MD	DN 100	4	50 - 60	8	16	3 x 2.5 + 2.5	80	65
AL-1102/2 MD	DN 100	7,5	50 - 60	14	25	3 x 6 + 6	117	74
AL-1129/4 MD	DN 125	4	50 - 60	8	16	3 x 2.5 + 2.5	142	64
AL-1129/4 MD	DN 125	5,5	50 - 60	11	20	3 x 6 + 6	179	64
AL-1129/4 MD	DN 125	7,5	50 - 60	14	25	3 x 6 + 6	191	65
AL-1154/4 MD	DN 150	7,5	50 - 60	14	25	3 x 6 + 6	204	65

1) Allowed fluctuation for supply voltage +/- 15%

2) The fuse must be of type gG and the circuit breaker must follow the C or D curve

3) Longer cables should be dimensioned to consider local conditions and installation regulations.



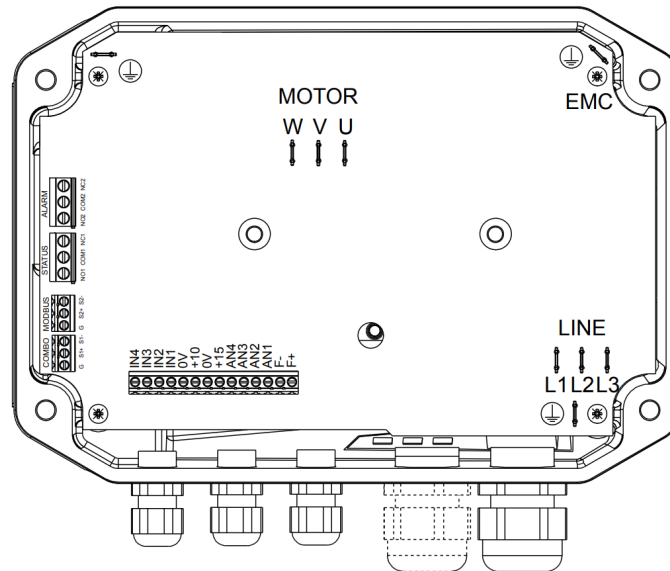

**MD-pumps, frequency converter with 3 X 380 – 460 V supply voltage 0,9 – 4,0 kW**

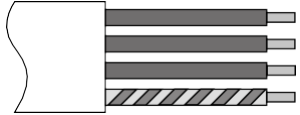
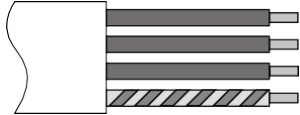
		<b>A [mm]</b>	<b>Pre-insulated cable lug</b>	<b>stripping diagram</b>
Power supply <b>LINE</b>	<b>L1</b>	70	6.3 x 0.8 mm female Faston	 <p style="text-align: center;"><b>A</b></p>
	<b>L2</b>	70	6.3 x 0.8 mm female Faston	
	<b>L3</b>	70	6.3 x 0.8 mm female Faston	
	<b>P.E.</b> ⊕	70	6.3 x 0.8 mm female Faston	
Motor supply (Includes to Kolmek's delivery) <b>MOTOR</b>	<b>U</b>	120 (200)	6.3 x 0.8 mm female Faston	 <p style="text-align: center;"><b>A</b></p> <p style="text-align: center;">Wall installation</p>
	<b>V</b>	120 (200)	6.3 x 0.8 mm female Faston	
	<b>W</b>	120 (200)	6.3 x 0.8 mm female Faston	
	<b>P.E.</b> ⊕	180 (200)	6.3 x 0.8 mm female Faston	Installation on board the motor  <b>(A)</b>

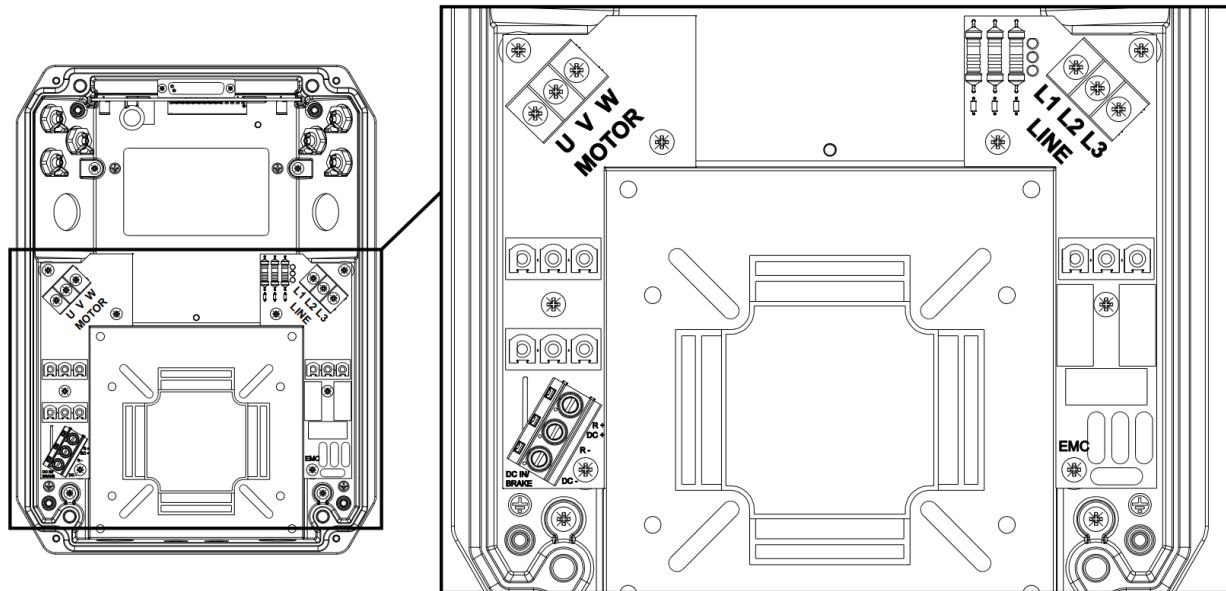
**MD-pumps, frequency converter with 3 X 380 – 460 V supply voltage 0,9 – 4,0 kW**

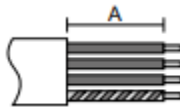
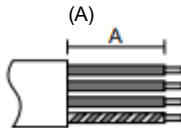
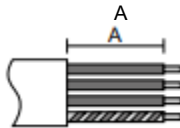
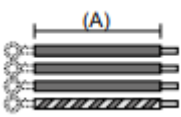
		A [mm]	Pre-insulated cable lug	stripping diagram
Power supply <b>LINE</b>	<b>L1</b>	180 (120)	Fork for M4 screw	Wall installation (through lower cable glands) A 
	<b>L2</b>	180 (120)	Fork for M4 screw	
	<b>L3</b>	180 (120)	Fork for M4 screw	
	<b>P.E. ⊕</b>	180 (120)	Eyelet for M4 screw	Installation on motor (through lateral cable glands) (A) 
Motor supply (Includes to Kolmeks delivery) <b>MOTOR</b>	<b>U</b>	180 (180)	Fork for M4 screw	Wall installation 
	<b>V</b>	180 (180)	Fork for M4 screw	
	<b>W</b>	180 (180)	Fork for M4 screw	
	<b>P.E. ⊕</b>	180 (180)	Eyelet for M4 screw	Installation on board the motor (A) 

### 3.3 Pump identification

Markings for accessories:

T = external mechanical seal for aggressive medium

H = flush for mechanical seal

KT = double mechanical seal

Sn = different mechanical seal





Kn = different surface treatment

Different material of impeller:

PM = Bronze CuSn10

SS = Stainless steel AISI316

Pump type  
Serial number, Nominal pressure  
Duty point, Max. medium temperature  
Motor type  
Nominal voltage and

<b>Pump L-50D/2 MDC</b>		<b>N662207</b>	
<small>LS0D2MD15V-00003</small>			
<b>No 225407.100-1 2022 PN10 Ø 130 mm</b>			
<b>6,93 l/s 9,5 m +120 °C MEI ≥ 0,4 --,-</b>			
<b>Motor KP-90-1 F16</b>		<b>Isol F IP54 IE3-86,2%</b>	
	$U_n$	$I_n$	$I_{max}$
	400 V	3,22 A	5,1 A
	230 V	5,6 A	8,8 A
<b>D 6305-VVC3E</b>		<b>N 6205-VVC3E</b>	
			

Motor code  
Impeller size  
Minimum efficiency index  
Electrical power at duty point  
Number of phases | Continuous duty  
Insulation and enclosure class | Motor efficiency  
Nominal shaft power | Motor speed  
Power factor  
Bearing types, CE -marking

AL - 110 2 / 4 MD B

L P - 50 B / 2 MD C

#### Pump series:

AE-, L-, AL-

#### Material of pump housing, sealing flange and impeller:

no letter = grey cast iron EN-GJL-200 / 10 bar

H = nodular cast iron EN-GJS-400 / 16 bar

P = bronze CuSn10 / 10 bar

S = stainless steel AISI 316 / 16 bar

#### Flange size, DN-size:

25 = 1"

32 = DN 32

40 = DN 40

50 = DN 50

65 = DN 65

80 = DN 80

1102 = DN 100

1129 = DN 125

1154 = DN 150

#### Poles of the electric motor:

2 = rotation speed 50 r/s (50 Hz)

4 = rotation speed 25 r/s (50 Hz)

ATTN! Motor speed is varying according to variable speed drive output frequency

#### MD = MD the frequency converter is integrated to the pump:

#### Control method:

MDA, MDB, MDC, MDD, MDF, MDG (check *Control methods and connections*)

## 4. Safety

This manual includes important information concerning installation and operating the pump. Persons who are involved in installation or/and operation of the pump, should read and understand these instructions before installation or starting the pump.



There are live parts inside the frequency converter of the VS -pump, when the supply voltage is connected. Incorrect installation of VS –pump may cause damage to the pump or bodily injuries, even death. Touching the live parts may be mortal even the supply voltage is disconnected. Obey instructions of this manual and national and local requirements and standards. Electric motor connection space and frequency converter motor output are under voltage, when supply voltage is connected, no matter if motor is stopped or not.

**Wait at least 10 minutes after disconnecting the supply voltage before opening the cover!**

- installation must be protected by fuses and insulated correctly.
- If MD-pumps Safety Extra Low Voltage (SELV) and relay output connection, automation and I/O cable gland is used other cable inlets as M12 cable glands equipped with 360° cable shield grounding, should end user isolate shielded cable metal cover for avoiding unexpected contact to Printed Circuit Board (PCB) and electric motor connection board, which are parts under voltage. In addition to previous, end user should take care of proper grounding of cable shield. In case of 4 kW and smaller MD-pumps M20 cable inlet enters the the device to Low Voltage (LV) side of PCB, where might occur dangerous voltages. M20 cable inlet is not recommended for SELV and relay output, automation and I/O connections. In case of using M20 cable inlet with 4 kW and smaller MD-pump connections, should end user take care of proper isolating the metal shield of the cable for avoiding the contact to PCB LV-side and electric motor connection board pins, which are parts under. Cable shield isolation should continue until SELV area. SELV area and LV area are marked with dotted line in the PCB.
- covers and cable inlets (with EMC cable glands) must be installed.
- 1 X 230 V supply voltage units phase connector and neutral connector need to be shielded with ferrite ring included to the delivery. This ensures fulfilling EMC C1 requirement fulfilling.

ATTN!

It is user's or certified electrician's responsibility to ensure the correct earthing and protection in accordance with applicable national and local requirements and standards.

## 4.1 Safety instructions

1. MD-pump must be disconnected from the mains if repair work is to be carried out. Check that the mains supply has been disconnected and necessary time has passed (at least 10 minutes).
2. The device must be connected correctly to the earth. User must be protected from supply voltage and the pump must be protected from short circuit according to the national and local requirements and standards. The overload protection is included in MD -pump.
3. Earth leakage is more than 3,5 mA. It means, that installation of supply cable must be fixed.

## 4.2 Training

The persons who have responsibility for installing or/and operating the pump, should be trained.

## 4.3 Elements of danger if safety regulations are not obeyed

If the safety regulations are not obeyed, personal injuries or damage to the pump or related devices may occur. Valid safety instructions must be obeyed.

## 4.4 Safety instructions for inspection and assembly

it is user's responsibility to ensure that persons who carry out inspections and installations are qualified experts and familiarized themselves with these instructions carefully.

## 4.5 Operating the pump

Working safety of the delivered pump and related devices can be ensured only if these devices are operated according to the section *1.2 Fields of application* and *1.3 Limits of application* and use of this manual.

# 5. Installation, introduction and start-up

The pump can be installed to the piping without separate supporting.

The position of the motor unit with the frequency converter can be changed by removing the motor unit from the pump housing and setting it to the desired position with certain limitations.

When installing the pump pay attention to the following:

- space enough for service and inspection of the pump
- assembly position should be considered to optimize Bluetooth connection from mobile application to the drive unit
- free visibility to the rating plate of the pump.
- possibility to use lifting mechanism if needed
- shut-off valves on the both sides of the pump
- the frequency converter is not too close hot pipes.

## 5.1 Positions for installation

### Allowed positions

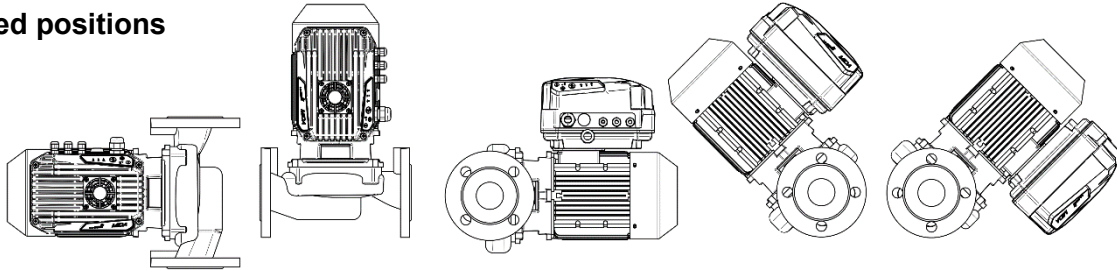

### Not allowed positions

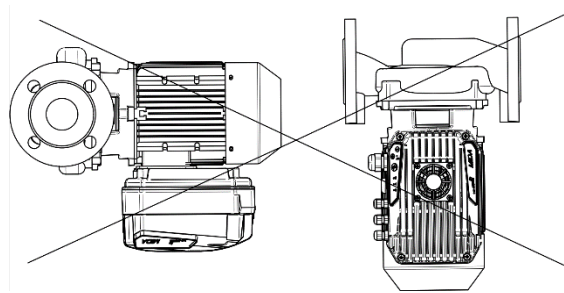

## 5.2 Electrical connections

### 5.2.1 Low voltage connections

ATTN!

All electrical work shall be carried out by qualified electrician approved by the local authorities. Supply voltage can be connected with non-shielded cable. Ensure the nominal voltage of the electric motor corresponds the local supply voltage. Kolmeks will not guarantee electric motor and frequency converter compatibility, if the user dismantles frequency converter power unit and replaces it with mechanically similar power unit. In such case power units may have different supply voltages. Check frequency converter user manual pages 11-12.

ATTN!

Before starting the pump fill and vent the system. Make sure that the pump rotates freely by rotating it manually eg. from the motor fan.

Never start or let the pump run dry. The warranty doesn't cover failures in the mechanical seal caused by dry running. Before starting the pump fill and vent the system. After starting make sure that there is no extra noise coming from the pump and that no leakages appear.

In MD-pumps exists hazardous voltages when the drive is energized. MD pump is not allowed to be used the cover removed from the bottom part.

**Wait at least 10 minutes after disconnecting the supply voltage before opening the cover!**

### 5.2.2 Safety extra low voltage (SELV) connections



In power range 0,37 kW – 4,0 kW, frequency converters MIDA205 – MIDA409 have low voltage (LV) and safety extra low voltage (SELV) connections in the same printed circuit board. MD-pump is not allowed to be used the cover, including the power board, removed from the aluminum bottom part, because there occurs hazardous contact voltages and working the cover open is working with live voltage.

**Wait at least 10 minutes after disconnecting the supply voltage before opening the cover!**

ATTN!

Always use screened control cables.

The shields of control cables and cable pairs should be insulated from those parts, which intersect low voltage area. The border of Low voltage and Safety extra low voltage areas is marked with white dotted line in power range 0,37 kW – 4,0 kW, drives MIDA205 – MIDA409.

The shield of control cable should be grounded either to the frame of the drive or to automation system PE rail.

Some of Kolmeks MD-pumps are equipped with metallic M12-M16 thread expander, which is connected to the frame of the drive. The shield of control cable can be grounded via metallic adapter to the frame of the drive.

In order to avoid interfering currents in the shield of control cable, it is not recommended to connect the shield to both frame of the drive and PE rail. The shields of cable pairs can be left floating, when is secured, that the shields are not in contact with parts under voltage.



### 5.3 Using MD-pump with Nastec Now mobile application or locally from keypad

MD-frequency converter can be controlled via Bluetooth connection with Nastec Now mobile application. Application can be downloaded from AppStore and Google Play stores free of charge. This manual contains QR-codes, which guide to application stores. Frequency converter basic operations (parametrizing and monitoring) are available without registration, but proper use of application requires registration.

In safety critical applications Bluetooth connection can be de-activated. Please contact Kolmeks representative, if the Bluetooth connection should be de-activated.

Please check instruction for registration from Appendix

Frequency converter set values (direct speed reference or PI-controller set point) can be changed from Nastec Now application or from frequency converter keypad.

In version with display is chosen with '+' and '-' buttons actual output frequency or pressure (difference) value. After this, '+'-button should be pressed 5 seconds until frequency or pressure (difference) value starts blinking. Blinking value indicates, that set value can be changed with '+' and '-' buttons to meet process requirements. After finding suitable set value, user should wait until the value stops blinking.

In version without display can be adjusted set value according to operation mode of the pump (in MDA-version frequency reference and in MDB- / MDC-versions pressure difference set value). When changing set value, '+'-button should be pressed 5 seconds until 'SET'-LED is continuously on. Continuously active LED indicates, that set value can be changed with '+' and '-' buttons to meet process requirements. Frequency reference is changed in (1) Hz steps and pressure (difference) 0,1 bar steps. After finding suitable set value, user should wait until the SET-LED stops being continuously on. This takes about 1 minute

### 5.4 Regular rotation of the pump

In case MD-pump is not actively used or MD-pump is operating as a back-up pump, pump should be rotated with 14 days interval minimum 10 minutes with Kolmeks factory setting frequency converter minimum frequency.

The purpose of regular rotation is to make sure proper operation of mechanical seal and if needed to make an alarm of pump glocking.

## 5.5 Control methods

### 5.5.1 MDA-pump – Frequency reference for frequency converter

#### **Applications**

Systems, where the duty point remains constant and where is no need for continuous automated regulation.

#### **Accessories**

Pump and frequency converter.

#### **Operation principle**

Pump speed should be set in 1 Hz steps from frequency converter keypad or from mobile application. In version with display is chosen with '+' and '-' buttons actual output frequency value. After this '+'-button should be pressed 5 seconds until frequency value starts blinking. Blinking value indicates, that set value can be changed with '+' and '-' buttons to meet process requirements. After finding suitable frequency value, user should wait until the value stops blinking.

In version without display should be pressed '+'-button should be pressed 5 seconds until 'SET'-LED is continuously on. Continuously active LED indicates, that frequency value can be changed with '+' and '-' buttons to meet process requirements. After finding suitable set value, user should wait until the SET-LED stops being continuously on. This takes about 1 minute.

Frequency reference can be set also with mobile application. From proximity of controlled pump the mobile application should be connected to the frequency converter with Bluetooth connection. While connecting the mobile application and frequency converter, the passwords are 001 and 002. After connecting, the user should choose from 'Program'-menu 'control'-tab 'Operating frequency'. suitable value should be written, pressed 'OK' and finally saved to frequency converter by pressing 'WRITE'. Please note, that pump should be stopped, when values are written with mobile application.

#### **Pump curve**

QH-curve of the pump is equal with that of single speed pump.

## 5.5.2 MDB- pump – constant pressure between the pump flanges

### Applications

Systems, where are variations in the flow and where pressure losses are generated mainly on the consumption equipment. Heating circulation, where the pressure loss on the heat equipment is small.

### Accessories

Pump, frequency converter, 2 pcs of pressure transmitters installed to the pump flanges.

### Operation principle and flow adjustment

Pressure difference should be kept constant between pump flanges. The level of the constant pressure difference between the pump flanges can be adjusted by 0,1 m steps from frequency converter keypad or from mobile application.

In version with display is chosen with '+' and '-' buttons actual pressure difference value. After this '+' button should be pressed 5 seconds until pressure difference value starts blinking. Blinking value indicates, that set value can be changed with '+' and '-' buttons to meet process requirements. After finding suitable pressure difference value, user should wait until the value stops blinking.

In version without display should be pressed '+'-button should be pressed 5 seconds until 'SET'-LED is continuously on. Continuously active LED indicates, that pressure difference value can be changed with '+' and '-' buttons to meet process requirements. After finding suitable pressure difference value, user should wait until the SET-LED stops being continuously on. This takes about 1 minute.

Pressure difference reference can be set also with mobile application. From proximity of controlled pump the mobile application should be connected to the frequency converter with Bluetooth connection. While connecting the mobile application and frequency converter, the passwords are 001 and 002. After connecting, the user should choose from 'Program'-menu 'control'-tab 'Set value [m]'. suitable value should be written, pressed 'OK' and finally saved to frequency converter by pressing 'WRITE'. Please note, that pump should be stopped, when values are written with mobile application.

### Pump curve

QH-curve of the pump is controlled to a horizontal line, which is suitable for systems with low pressure loss share in heat exchanger compared to the total pressure loss.

### 5.5.3 MDC- pump - constant pressure in between inlet- and outlet-line

#### **Applications**

Systems, where are variations in the flow and where pressure losses are generated mainly on the source of heat equipment. Heating and cooling circulations and the pressure boosting of parallel circulations.

#### **Accessories**

Pump, frequency converter and 2 pcs of pressure transmitters. Another transmitter to be installed to the suction or pressure flange of the pump and another one on to the system inlet or outlet pipe.

#### **Operation principle and flow adjustment**

Pressure difference should be kept constant between inlet and outlet pipeline. The level of the constant pressure difference between the pipe lines can be adjusted by 0,1 m steps from frequency converter keypad or from mobile application.

In version with display is chosen with '+' and '-' buttons actual pressure difference value. After this '+'-button should be pressed 5 seconds until pressure difference value starts blinking. Blinking value indicates, that set value can be changed with '+' and '-' buttons to meet process requirements. After finding suitable pressure difference value, user should wait until the value stops blinking.

In version without display should be pressed '+'-button should be pressed 5 seconds until 'SET'- is continuously on. Continuously active LED indicates, that pressure difference value can be changed with '+' and '-' buttons to meet process requirements. After finding suitable pressure difference value, user should wait until the SET-LED stops being continuously on. This takes about 1 minute.

Pressure difference reference can be set also with mobile application. From proximity of controlled pump the mobile application should be connected to the frequency converter with Bluetooth connection. While connecting the mobile application and frequency converter, the passwords are 001 and 002. After connecting, the user should choose from 'Program'-menu 'control'-tab 'Set value [m]'. suitable value should be written, pressed 'OK' and finally saved to frequency converter by pressing 'WRITE'. Please note, that pump should be stopped, when values are written with mobile application.

#### **Pump curve**

QH-curve of the pump is controlled to a quadratic. The relation of pressure loss in the source of heat (cold) to the loss in the system defines the shape of the curve. When the losses in the heat exchanger are large part of the whole losses in the system the curve is more steep.

#### 5.5.4 MDD- pump - constant pressure in discharge (pressure boosting)

##### **Applications**

Pressure boosting or other open systems, where constant pressure is required.

##### **Accessories**

Pump, frequency converter and pressure transmitter. The pressure transmitter is installed to the pressure flange of the pump or near to the consumption in the pipe line.

##### **Operation principle**

Constant pressure should be kept in in pump outlet. The level of the constant pressure in pump outlet can be adjusted by 0,1 m steps from frequency converter keypad or from mobile application.

In version with display is chosen with '+' and '-' buttons actual pressure value. After this '+'-button should be pressed 5 seconds until pressure value starts blinking. Blinking value indicates, that set value can be changed with '+' and '-' buttons to meet process requirements. After finding suitable pressure value, user should wait until the value stops blinking.

In version without display should be pressed '+'-button should be pressed 5 seconds until 'SET'-LED is continuously on. Continuously active LED indicates, that pressure value can be changed with '+' and '-' buttons to meet process requirements. After finding suitable pressure value, user should wait until the SET-LED stops being continuously on. This takes about 1 minute.

Pressure reference can be set also with mobile application. From proximity of controlled pump the mobile application should be connected to the frequency converter with Bluetooth connection. While connecting the mobile application and frequency converter, the passwords are 001 and 002. After connecting, the user should choose from 'Program'-menu 'control'-tab 'Set value [m]'. suitable value should be written, pressed 'OK' and finally saved to frequency converter by pressing 'WRITE'. Please note, that pump should be stopped, when values are written with mobile application.

### 5.5.5 MDF- pump - constant temperature

#### Applications

Heating and cooling systems, where the constant temperature is required by adjusting the flow.

#### Accessories

Pump, frequency converter and temperature transmitter (and sensor).

#### Operation principle

Constant temperature should be kept in process. The level of the constant temperature in pump outlet can be adjusted by 1 °C steps from frequency converter keypad or from mobile application.

In version with display is chosen with '+' and '-' buttons actual temperature value. After this '+'-button should be pressed 5 seconds until temperature value starts blinking. Blinking value indicates, that set value can be changed with '+' and '-' buttons to meet process requirements. After finding suitable temperature value, user should wait until the value stops blinking.

In version without display should be pressed '+'-button should be pressed 5 seconds until 'SET'-LED is continuously on. Continuously active LED indicates, that temperature value can be changed with '+' and '-' buttons to meet process requirements. After finding suitable temperature value, user should wait until the SET-LED stops being continuously on. This takes about 1 minute.

Temperature reference can be set also with mobile application. From proximity of controlled pump the mobile application should be connected to the frequency converter with Bluetooth connection. While connecting the mobile application and frequency converter, the passwords are 001 and 002. After connecting, the user should choose from 'Program'-menu 'control'-tab 'Set value [°C]'. suitable value should be written, pressed 'OK' and finally saved to frequency converter by pressing 'WRITE'. Please note, that pump should be stopped, when values are written with mobile application.

**NOTE!** While ordering the pump, customer should announce the direction of adjustment.

*Direct:* when temperature actual value increases, pumping should be decreased (heating)

*Reverse:* when temperature actual value increases, pumping should be increased (cooling)

### 5.5.6 MDG- pump - controlled by external system

#### Applications

Systems, where are variations in the flow and/or where the flow is controlled mainly with the pump. The pump is controlled by an external system or controller.

#### Accessories

Pump and frequency converter.

#### Operation principle

The speed reference for pumps is given to Analogue input 1 (0-10 V) from external control system, external controller, process control, etc

**NOTE!** Pump will be stopped, when voltage signal decreases below 0,2 V.

## 6. Service, spare parts and troubleshooting

The pump doesn't need any regular servicing. As a shaft seal is used an adjustment free mechanical seal. It is a wearing part which has to be replaced if it starts to leak. Note that few drops leakage per hour can be quite normal especially when coolants (eg. glycol) are pumped.

### 6.1 Shaft seals

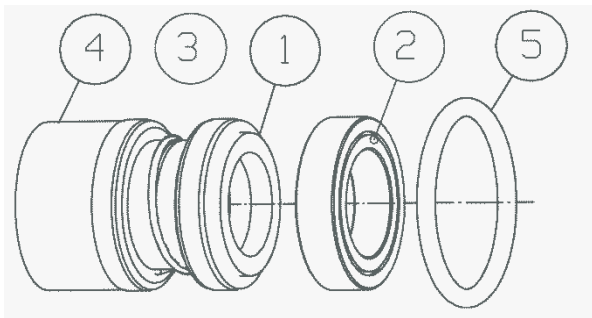

Pump type	Shaft mm	O-ring mm
AE_-25/-26 VS_	12	123x2,5
L_-32A VS_	12	100x2,5
L_-40A, AE_-32/-33 VS_	12	145x2,5
L_-50A VS_	12	150x3
L_-65A, L_-80A, AL_-1102 VS_	18	179,3x5,7
L_-100S VS_	32	315x6,3
AL_-1129 VS_	32	309/295 x 1
AL_-1154 VS_	32	309/295 x 1

- 1 Rotating ring
- 2 Stationary ring
- 3 Body / bellows
- 4 Spring
- 5 O-ring

The motor is equipped with ball bearings which are lubricated for life and therefore do not need any service. In the case of any motor malfunction, it is recommended to replace the whole motor unit.

## 6.2 Other parts

- 1 Electric motor
- 2 Pump housing
- 3 Impeller
- 5 Sealing flange
- 8 Foot (not always)
- 24 Screw or nut
- 25 Washer
- 26 Key
- 40 Shaft seal
- 50 O-ring or gasket
- 60 Screw or nut
- 67 Screw
- 80 Pipe union (L- and ALH -series)
- 81 Pipe union (L- and ALH -series)
- 86 Cooling pipe (L- and ALH -series)
- 103 Frequency converter
- 111 Transmitter(s) (pressure to temperature)
- 112 Quick connector of transmitter(s)

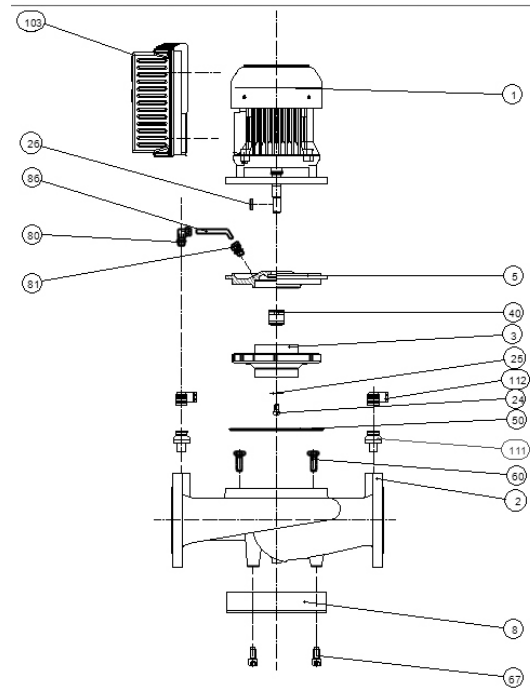

ATTN!

**WHEN ORDERING SPARE PARTS, PLEASE SPECIFY THE TYPE IDENTIFICATION, SERIAL NUMBER, THE SIZE OF THE IMPELLER, THE MOTOR TYPE AND POWER AND THE POSITION NUMBER OF THE SPARE PART.**



### 6.3 Troubleshooting

<b>Trouble</b>	<b>Fault</b>	<b>Fixing</b>
<b>Shaft seal is leaking.</b>	Wearing.	Change the seal.
	Pump has run dry.	Change the seal.
<b>Pump doesn't run.</b>	The shaft of the pump is blocked.	Check the free rotation of the shaft by turning the motor fan. If required, loosen the motor unit from the pump housing and repair the cause of the block.
	Fuses have worked.	Repair the cause of the fault. Change the fuses. If necessary, call the expert.
	No electricity.	Check and repair connections. If necessary, call the expert.
	The disorder has stopped the pump.	Reset the pump by disconnecting the supply voltage at least for 10 seconds.
	Control wiring is not correct.	Check the wiring in accordance with the control diagram. Between terminals 0V and IN1 must be jumpered or closed switch.
	The parameters of the frequency converter are changed or the pump is stopped locally.	Correct the parameters or start the pump locally from 'Start/Stop'-button. If necessary, call the expert.
	The frequency converter or electric motor is damaged.	Replace the frequency converter and/or electric motor with a new one. Contact to Kolmek.
<b>ATTN!</b>	If the pump is operated when cover of the frequency converter is open, the special carefulness must be observed.	
<b>Pump stops by itself or runs irregular and noisy.</b>	The supply voltage is defective. One phase is possible missing.	Check the supply voltage. Check and repair fuses and connections of the cables.
	The frequency converter or electric motor is damaged.	Replace the complete motor unit with frequency converter with a new one. Contact to Kolmek.

Trouble	Fault	Fixing
<b>The pump is running with minimum frequency.</b>	The reference value is missing or in minimum.	Adjust the correct value with the buttons of the local control panel or with mobile application. Check and correct the reference if the reference is given by external controller.
	The pipes of the pressure or differential pressure transducer are blocked or incorrectly connected.	Check and repair the connections and blockings of the pipes. Open the possible valves, which are installed to the pipes.
	The signal of the feedback transmitter (pressure or temperature) is too high. Possible short circuit.	Check transmitter actual value from mobile application monitoring. Check the connections, transmitter. If necessary, replace the transmitter with the new one.
	The mechanical or electrical connections of the temperature transmitter of the MDF -pump are incorrect or the transmitter is damaged.	Check and repair of the connections or the transmitter.
	Parameters of the MDF -pump are wrong (cooling and heating pumps have different parameters)	Check and correct the parameters. If necessary, call the expert.
	MDB or MDC –pump: The lower pressure transmitter gives the full signal (20 mA) or the higher pressure transmitter gives no signal.	Check the connections and transmitters. Measure the signals of the transmitter and if needed, change the transmitter.
<b>The pump is running only with the maximum frequency, which don't vary in accordance with the requirements of flow changes.</b>	Reference signal is too high.	Adjust the correct value with the buttons of the local control panel or from mobile application. Check and correct the reference if the reference is given by external controller.
	Feedback transmitter is missing or the signal is wrong	Check and repair the feedback signal and/or connections. If necessary, replace the transmitter with the new one.

	The pipes of the pressure or differential pressure transducer are blocked or incorrectly connected.	Check and repair the connections and blockings of the pipes. Open the valves, which may be installed to the pipes.
<b>Trouble</b>	<b>Fault</b>	<b>Fixing</b>
<b>The pump is running only with the maximum frequency, which don't vary in accordance with the requirements of flow changes.</b>	The mechanical or electrical connections of the temperature transmitter of the MDF -pump are incorrect or the transmitter is damaged.	Check and repair of the connections or the transmitter.
	Parameters of the MDF -pump are wrong. (cooling and heating pumps have different parameters)	Check and correct the parameters with the local control panel. If necessary, call the expert.
	The maximum speed is required by the system.	Check the adjustments and the need of the pumping in the system. Balance the parallel circulations. It can be the normal situation, then there is no need for any further measures. Solve the actual rotation speed by measuring or with the mobile application. Contact to Kolmeks. Maximum frequency is not allowed to change (factory default).
	MDB or MDC –pump: The higher pressure transmitter gives the full signal (20 mA) or the lower pressure transmitter gives no signal.	Check the connections and transmitters. Measure the signals of the transmitter and if needed, change the transmitter.

<b>Trouble</b>	<b>Fault</b>	<b>Fixing</b>
<b>The pump is not pumping.</b>	There is air in the pump or the system.	Deairate the system. Fill the pumps and the pipes with the fluid. Try to run the pump a moment with the high speed, then possible air pockets leave the system easier.
	The suction pressure is too low.	Increase the suction pressure.
	Circulation is closed with the valves.	Open the valves.
<b>The pump is noisy.</b>	Cavitation.	Increase the suction pressure. Decrease the flow.

	<p>The pressure difference of the pump is too high.</p>	<p>Decrease the pressure reference. If possible, open the control valves and decrease the pressure reference, then the head of the pump is lower and the flow remains the same.</p>
	<p>There is a faulty shaft seal or bearings.</p>	<p>Continuous rough noise refers to the faulty bearings. High noise, few seconds long, occasionally refers to the faulty shaft seal. Replace faulty bearings and shaft seal with the new ones. If necessary, contact Kolmeks.</p>
	<p>Electrical noise from the frequency converter or electric motor.</p>	<p>Replace the motor with the new one. If necessary, correct the parameters of the frequency converter. Contact Kolmeks.</p>

## 6.4 Alarm and warning codes

Alarm	Description	Possible solutions
LINE<->MOT INV.	Reverse the connection of the power cable and motor cable.	<ul style="list-style-type: none"> <li>Correct the connection of the power and motor cables.</li> </ul>
A01 Overcurrent motor	<p>The current absorbed by the motor exceeds the value set in the parameter Rated motor current.</p> <p>Reset mode:</p> <ul style="list-style-type: none"> <li>Automatic reset after 10 seconds for up to 7 attempts, after which you must wait for 60 minutes.</li> <li>Disconnecting the power supply.</li> </ul>	<ul style="list-style-type: none"> <li>Verify that the value set for the parameter Rated motor current corresponds at least to the rated current of the motor according to its rating plate data.</li> </ul> <p><b>NOTE</b> The voltage drop across the inverter (variable between 20 and 40 VAC) causes the motor to be powered at a slightly lower voltage than the one stated on the data plate. The current absorbed by the motor could therefore be slightly higher than the rated current indicated in data plate and, to obtain maximum performance, it is necessary to increase the parameter Rated motor current between 5% and 10%.</p> <p><b>WARNING</b> Check with the motor manufacturer the tolerability to withstand a current greater than its rated current.</p> <ul style="list-style-type: none"> <li>Check that all the motor phases are correctly connected and that the connection is suitably configured in Star or Delta.</li> <li>Check that motor parameters are correctly set.</li> <li>In devices with FOC control, perform a new motor calibration.</li> <li>In the presence of output filters (dV / dt or sinusoidal), check that they are correctly connected and, in devices with FOC control, check that you have correctly set the parameters PWM and FOC dynamics in relation to the length of the motor cable and the type of filter used.</li> <li>Check that the pump is turning in the correct direction.</li> <li>Make sure that the motor is free to rotate and check for any mechanical issues.</li> <li>Adjust parameter Voltage boost</li> </ul>
A02 Sensor fault	<p>The current value read by the analog input is less than 4 mA.</p> <p>Reset mode:</p> <ul style="list-style-type: none"> <li>Alarm reset by STOP key.</li> <li>Disconnecting the power supply</li> </ul>	<ul style="list-style-type: none"> <li>Check that the connections on the device side and on the sensor side are correct.</li> <li>Check that the sensor is fed the correct power.</li> <li>Check that the sensor is working properly.</li> <li>If only one sensor is connected to analog input 1, try to connect it to analog input 2.</li> </ul>
A03 Over temperature inverter	<p>The temperature reached by the device is higher than the maximum allowed value.</p> <p>Reset mode:</p> <ul style="list-style-type: none"> <li>Automatic reset</li> </ul>	<ul style="list-style-type: none"> <li>Check that the ambient temperature is within the allowed limits.</li> <li>Make sure the device is protected from direct exposure to sunlight or heat sources.</li> <li>Check that both the external and internal cooling fans (if present) are working properly.</li> <li>Check that the dissipation channels are clean.</li> <li>Check that the device is cooled as indicated in the dedicated chapter.</li> <li>Reduce parameter PWM as much as possible.</li> </ul> <p><b>NOTE</b> To ensure uninterrupted operation, the inverter automatically reduces the maximum frequency (i.e. power) when the internal temperature reaches a certain threshold. If such frequency reduction is not sufficient to keep the temperature above the maximum permitted value, the inverter will stop the motor and trigger the alarm A03 Over temperature inverter.</p>

<p>A04 Dry run cosphi</p>	<p>The warning W26 No water appeared 5 consecutive times following the automatic reset attempts. Reset mode:</p> <ul style="list-style-type: none"> <li>• Alarm reset by STOP key.</li> <li>• Disconnecting the power supply</li> </ul>	<p><b>WARNING</b> When the warning W26 No water appears, the device will automatically restart the load after a time equal to the value set in the parameter Restarts delay multiplied by the number of attempts made. At the end of the fifth attempt, the device will definitively stop the load producing the alarm A04 Dry run cosphi. The alarm must be reset manually.</p>
<p>A05 Under voltage</p>	<ul style="list-style-type: none"> <li>• Supply voltage below the minimum allowed value.</li> <li>• Insufficient input power to power the device.</li> </ul> <p>Reset mode:</p> <ul style="list-style-type: none"> <li>• Automatic reset if parameter Autorestart = ON</li> </ul>	<ul style="list-style-type: none"> <li>• Check the value of the power supply voltage both under no load and load conditions.</li> <li>• Verify that the source has enough power to power the load.</li> </ul>
<p>A06 Over voltage</p>	<p>The power supply voltage or the voltage inside the device exceeds the maximum allowed value. Reset mode:</p> <ul style="list-style-type: none"> <li>• Automatic reset if parameter Autorestart = ON</li> </ul>	<ul style="list-style-type: none"> <li>• Check the value of the power supply voltage both under no load and load conditions.</li> <li>• Check for regeneration from the load.</li> <li>• Increase parameter Ramp down</li> <li>• Increase parameter Ramp freq. min motor</li> <li>• In the case of a permanent magnet motor, check that the load is not subjected to passive movement.</li> </ul>
<p>A07 Max value alarm</p>	<p>The value read by the analog input is higher than the value set for the parameter Max alarm value. Reset mode:</p> <ul style="list-style-type: none"> <li>• Automatic reset</li> </ul>	<ul style="list-style-type: none"> <li>• Check the value set for the parameter.</li> <li>• Check the hydraulic causes that lead to the alarm condition.</li> <li>• Check that the sensor is working properly.</li> </ul>
<p>A08 Locked rotor</p>	<p>The automatic frequency limitation created by the inverter following an excessive absorption by the motor (beyond the value set in the parameter Rated motor current) causes a reduction of the frequency below the average value between Min motor frequency and Max motor frequency. Reset mode:</p> <ul style="list-style-type: none"> <li>• Alarm reset by STOP key.</li> <li>• Disconnecting the power supply</li> </ul>	<ul style="list-style-type: none"> <li>• Check the possible solutions for the alarm A01 Overcurrent motor</li> </ul>
<p>A09 Overload inverter</p>	<p>The current absorbed by the load exceeds the rated current of the device. Reset mode:</p> <ul style="list-style-type: none"> <li>• Alarm reset by STOP key.</li> <li>• Disconnecting the power supply</li> </ul>	<ul style="list-style-type: none"> <li>• Check that the rated current of the motor is lower than the rated current of the device.</li> <li>• Make sure that the motor is free to rotate and check for any mechanical issues.</li> <li>• Increase the value of the parameter Ramp up time.</li> <li>• Increase the value of the parameter Ramp freq. min motor.</li> <li>• Adjust parameter Voltage boost</li> <li>• Check the value of the power supply voltage both under no load and load conditions.</li> </ul> <p><b>CAUTION</b> The device can supply power to the load for 10 minutes at a current consumption of 101 % of the rated current of the device, and for 1 minute at a current consumption of 110 % of the rated current of the device.</p>

A10 IGBT trip alarm	<p>The current absorbed by the load instantaneously exceeds the maximum current protection of the device's power module.</p> <p>Reset mode:</p> <ul style="list-style-type: none"> <li>• Automatic reset after 10 seconds for up to 3 attempts, after which you must wait for 60 minutes.</li> <li>• Disconnecting the power supply</li> </ul>	<ul style="list-style-type: none"> <li>• Check the possible solutions for alarms A01 Overcurrent motor and A09 Overload inverter.</li> <li>• Check for short circuits between the output phases and the ground insulation.</li> <li>• Check that the system is properly grounded.</li> <li>• Check for electrical noise from other devices connected to the system.</li> </ul>
A11 No load	<p>The current absorbed by the load is too low in relation to the parameter Rated motor current.</p> <p>Reset mode:</p> <ul style="list-style-type: none"> <li>• Alarm reset by STOP key.</li> <li>• Disconnecting the power supply</li> </ul>	<ul style="list-style-type: none"> <li>• Check the possible solutions for the alarm A01 Overcurrent motor</li> </ul>
A12 Address error	<p>In COMBO mode, multiple devices in the group have the same address.</p> <p>Reset mode:</p> <ul style="list-style-type: none"> <li>• Automatic reset</li> </ul>	<ul style="list-style-type: none"> <li>• Restore the correct value of parameter Address COMBO in all the devices in the group.</li> <li>• Verify which situation triggers the alarm.</li> <li>• If the alarm is triggered after a master replacement, check that the parameter Autorestart is activated.</li> <li>• Check the electrical connection between the slave unit and the master, and the presence of possible disturbances.</li> </ul>
A13 No communication	<p>In COMBO mode, the communication between the slave unit and the master has been interrupted.</p> <p>Reset mode:</p> <ul style="list-style-type: none"> <li>• Automatic reset</li> </ul>	<ul style="list-style-type: none"> <li>• Check the electrical connection between the slave unit and the master, and the presence of possible disturbances.</li> <li>• Exit the master programming menu.</li> <li>• Attempt a manual reset of the alarm.</li> </ul> <p><b>CAUTION</b> Keep signal cables separate and never parallel to power cables. If it is necessary to cross them, make sure that they cross perpendicularly.</p>
A14 Min value alarm	<p>The value read by the analog input is lower than the value set for the parameter Min alarm value.</p> <p>Reset mode:</p> <ul style="list-style-type: none"> <li>• Automatic reset</li> </ul>	<ul style="list-style-type: none"> <li>• Check the value set for the parameter.</li> <li>• Check the hydraulic causes that lead to the alarm condition.</li> <li>• Check that the sensor is working properly.</li> </ul>
A15 Keyboard fault	<p>One of the keys of the keyboard was held down for more than 30 seconds.</p> <p>Reset mode:</p> <ul style="list-style-type: none"> <li>• Alarm reset by STOP key.</li> <li>• Disconnecting the power supply</li> </ul>	<ul style="list-style-type: none"> <li>• Check that the keys are mechanically free.</li> </ul>
A16 CPU alarm	<p>Communication error between the control part and the power part or error in the CPU.</p> <p>Reset mode:</p> <ul style="list-style-type: none"> <li>• Automatic reset</li> </ul>	<ul style="list-style-type: none"> <li>• Check the value of the power supply voltage both under no load and load conditions.</li> <li>• Check for electrical noise from other devices connected to the system.</li> <li>• Check the integrity of the communication cable between the control board and the power board.</li> </ul>
A17 Brake alarm	<p>In devices equipped with brakes, it indicates the achievement of the maximum energy that the braking resistor can withstand.</p> <p>Reset mode:</p> <ul style="list-style-type: none"> <li>• Automatic reset if parameter Autorestart = ON</li> </ul>	<ul style="list-style-type: none"> <li>• Check the possible solutions for the alarm A06 Over voltage .</li> </ul>
A19 Out of step	<p>With parameter Motor type set to Synchronous PM, the loss of motor control occurs.</p> <p>Reset mode:</p> <ul style="list-style-type: none"> <li>• Automatic reset with a 3-minute delay.</li> </ul>	<ul style="list-style-type: none"> <li>• Check the possible solutions for the alarm A01 Overcurrent motor</li> </ul>
A20 Input phase loss	<p>Absence of a power supply phase. Reset mode:</p> <ul style="list-style-type: none"> <li>• Automatic reset if parameter Autorestart = ON</li> </ul>	<ul style="list-style-type: none"> <li>• Check that all three power phases are present.</li> <li>• Check the balance of the power supply phases.</li> </ul>
A22 ALL. TEMP. MOT.	<p>The temperature measured by the PT100 or PT1000 probe has reached the value set in the parameter PT alarm and the device stops the engine.</p> <p>Reset mode:</p> <ul style="list-style-type: none"> <li>• Automatic reset when the temperature falls below the parameter PT restart.</li> </ul>	<ul style="list-style-type: none"> <li>• Check that the motor is cooled correctly.</li> <li>• Check the value set for the parameter PT alarm.</li> </ul>

Warning	Description	Possible solutions
W01 Digital input active 1	Digital input 1 has been activated.	<ul style="list-style-type: none"> <li>• Check the configuration and connections to digital input 1.</li> </ul>
W02 Digital input active 2	Digital input 2 has been activated.	<ul style="list-style-type: none"> <li>• Check the configuration and connections to digital input 2.</li> </ul>
W03 Digital input active 3	Digital input 3 has been activated.	<ul style="list-style-type: none"> <li>• Check the configuration and connections to digital input 3.</li> </ul>
W04 Digital input active 4	Digital input 4 has been activated.	<ul style="list-style-type: none"> <li>• Check the configuration and connections to digital input 4.</li> </ul>
W20 Temp. derate	The inverter is limiting the maximum motor frequency to keep the inverter temperature below the maximum limit.	<ul style="list-style-type: none"> <li>• Check the possible solutions for the alarm A03 Over temperature inverter.</li> </ul>
W21 Overload 15V	15V power supply overload.	<ul style="list-style-type: none"> <li>• Check the absorption of the loads and any short circuits connected to the 15V power supply</li> </ul>
W22 EEPROM COM.	No communication with EEPROM	<ul style="list-style-type: none"> <li>• Contact the technical support service.</li> </ul>
W23 EEPROM fault	Failure in EEPROM	<ul style="list-style-type: none"> <li>• Contact the technical support service</li> </ul>
W25 Alarm slave X	In control mode COMBO, the master has detected an alarm in the X slave.	<ul style="list-style-type: none"> <li>• Check the status of the XX slave unit indicated by the master.</li> </ul>
W26 No water	The power factor (cosphi) of the motor read by the device is permanently below the value set in the parameter Dry run cosphi.	<ul style="list-style-type: none"> <li>• Check that the pump is properly primed.</li> <li>• Check that the pump is turning in the correct direction.</li> <li>• Check that the parameter Dry run cosphi is set correctly.</li> </ul>
W27 START/STOP block	The START/STOP buttons have been locked.	<ul style="list-style-type: none"> <li>• Press the START or STOP button for at least 5 seconds to release the lock.</li> </ul>
W29 FREQ. RESTARTS	The engine has been restarted periodically too many times. This warning does not involve stopping the engine, but simply serves as an indication for checking the system.	<ul style="list-style-type: none"> <li>• Check that there are no leaks in the system.</li> <li>• Check the correct volume and pre-charge pressure of the expansion tank.</li> <li>• Check the correct setting of the parameters Delta start , Delta control , Delta stop , Control ramp</li> </ul>



## 7. Declaration of Conformity

We, KOLMEKS OY, P.O.Box 27 FI-14201 Turenki, FINLAND  
declare under our sole responsibility that the products:

**MD- - PUMP SERIE,**

types AE, AEP, L, LH, LP, LS, AL, ALH, ALP, ALS

to which this declaration relates, are in conformity with the

- Council Directive 2006/42/EY on the approximation of the laws of the Member States relating to machinery
- Low voltage directive 2014/35/EU
- Pumps and pump units for liquids. Common safety requirements. EN 809:1998+A1:2009.
- Ecodesing directive 2009/125/EY Regulations: 547/2012 for water pumps  
2019/1781 for electric motors
- RoHS-directive 2011/65/EU and 2015/863/EU

Serial / manufacturing number \_\_\_\_\_

### EMC-STANDARDS

Generic standards

The generic standards are stated in the EMC directive (2014/30/EU).

VS\_ -pump complies with:

EN 61000-6-3, EN 61000-6-1. Residential, commercial and light industrial environment.

EN 61000-6-4, EN 61000-6-2. Industrial environment.

Turenki 09.03.2023



Jyrki Vesaluoma  
Chairman of the board

Technical file collected by R&D manager

KOLMEKS OY  
P.O.BOX 27 FI-14201 TURENKI, FINLAND  
tel. +358 20 7521 31  
www.kolmeks.com  
[export.finland@kolmeks.com](mailto:export.finland@kolmeks.com)

### MINIMUM EFFICIENCY INDEX MEI

The efficiency of a pump with a trimmed impeller is usually lower than that of a pump with full impeller diameter. The trimming of the impeller will adapt the pump to a fixed duty point, leading to reduced energy consumption. The minimum efficiency index (MEI) is based on full impeller diameter.

The operation of this water pump with variable duty points may be more efficient and economic when controlled, for example, by the use of a variable speed drive that matches the pump duty to the system.

For pumps supplied after 1.1.2015 regulation 547/2012 is to be applied, Minimum Efficiency Index MEI > 0,4, benchmark for the most efficient water pumps is MEI > 0,7. Information on benchmark efficiency is available at: [www.europump.org/efficiencycharts](http://www.europump.org/efficiencycharts)

## 8. Annex

### 8.1 Wiring diagram MDA-single pump

#### 8.1.1 Wiring diagram MDA-single pump, 4 x Din

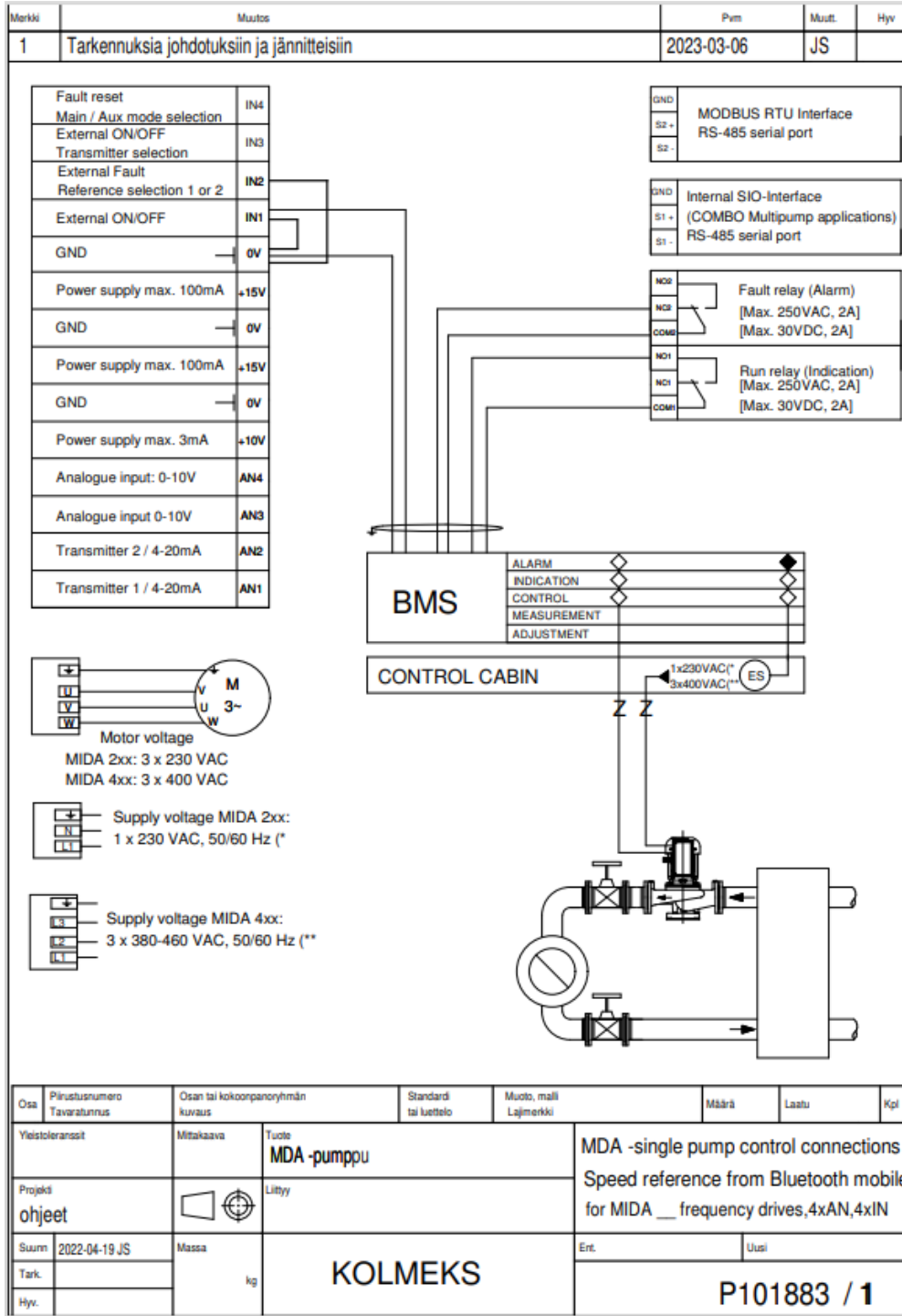

8.1.2 Wiring diagram MDA-single pump, 2 x Din

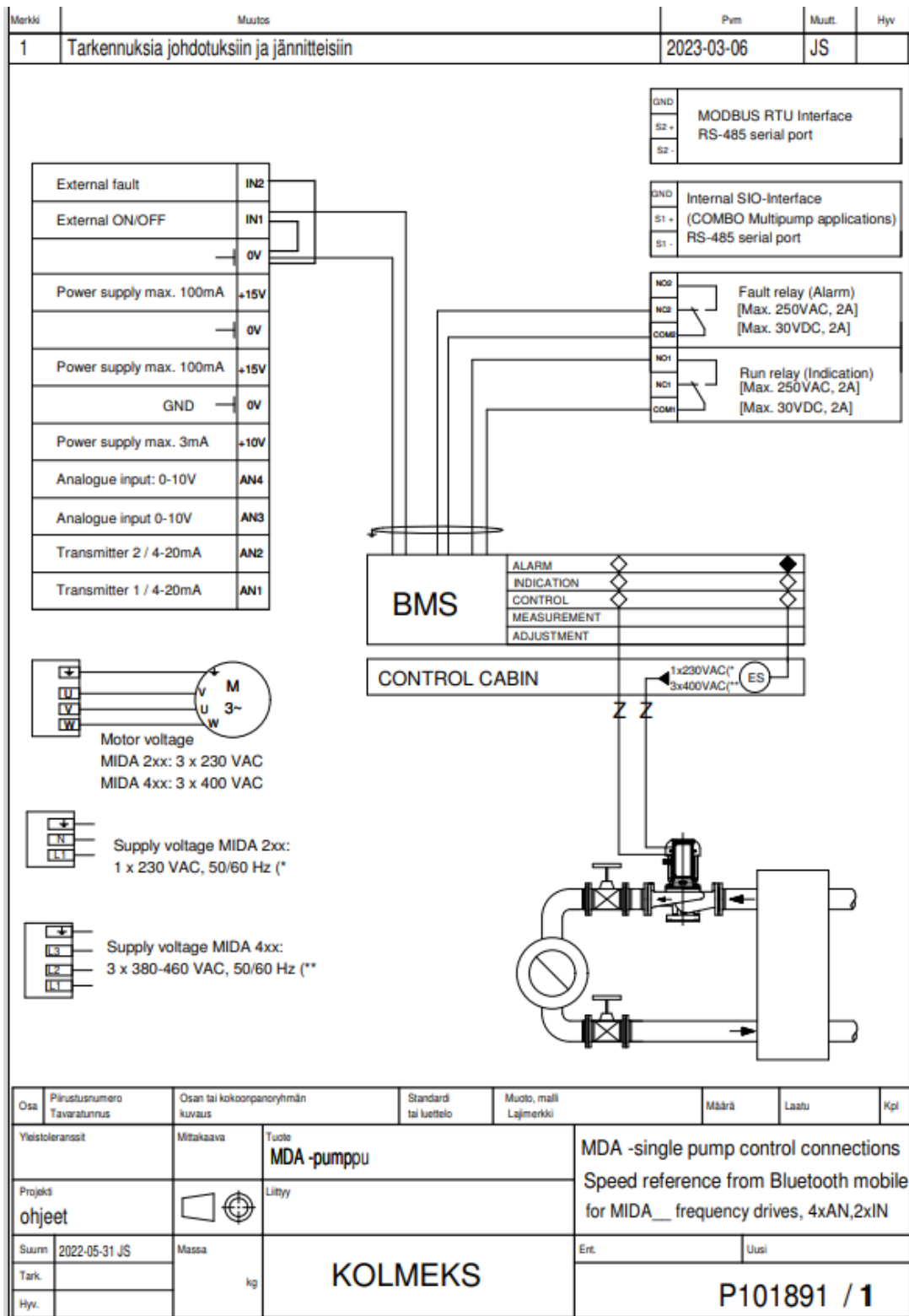







### 8.3.2 Wiring diagram MDC-single pump, 2 x Din

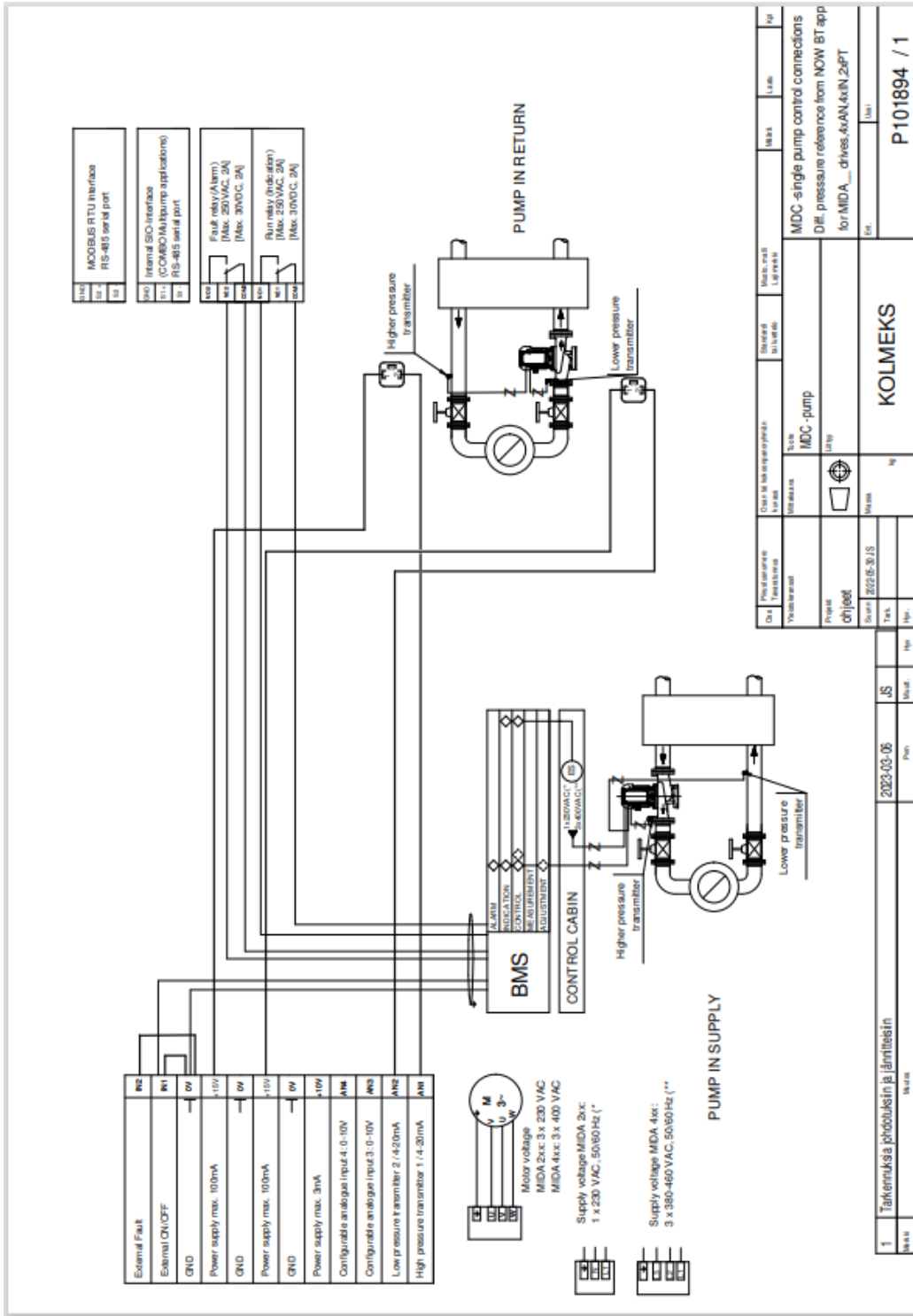

### 8.4 Wiring diagram MDD-single pump

#### 8.4.1 Wiring diagram MDD-single pump, 4 x Din

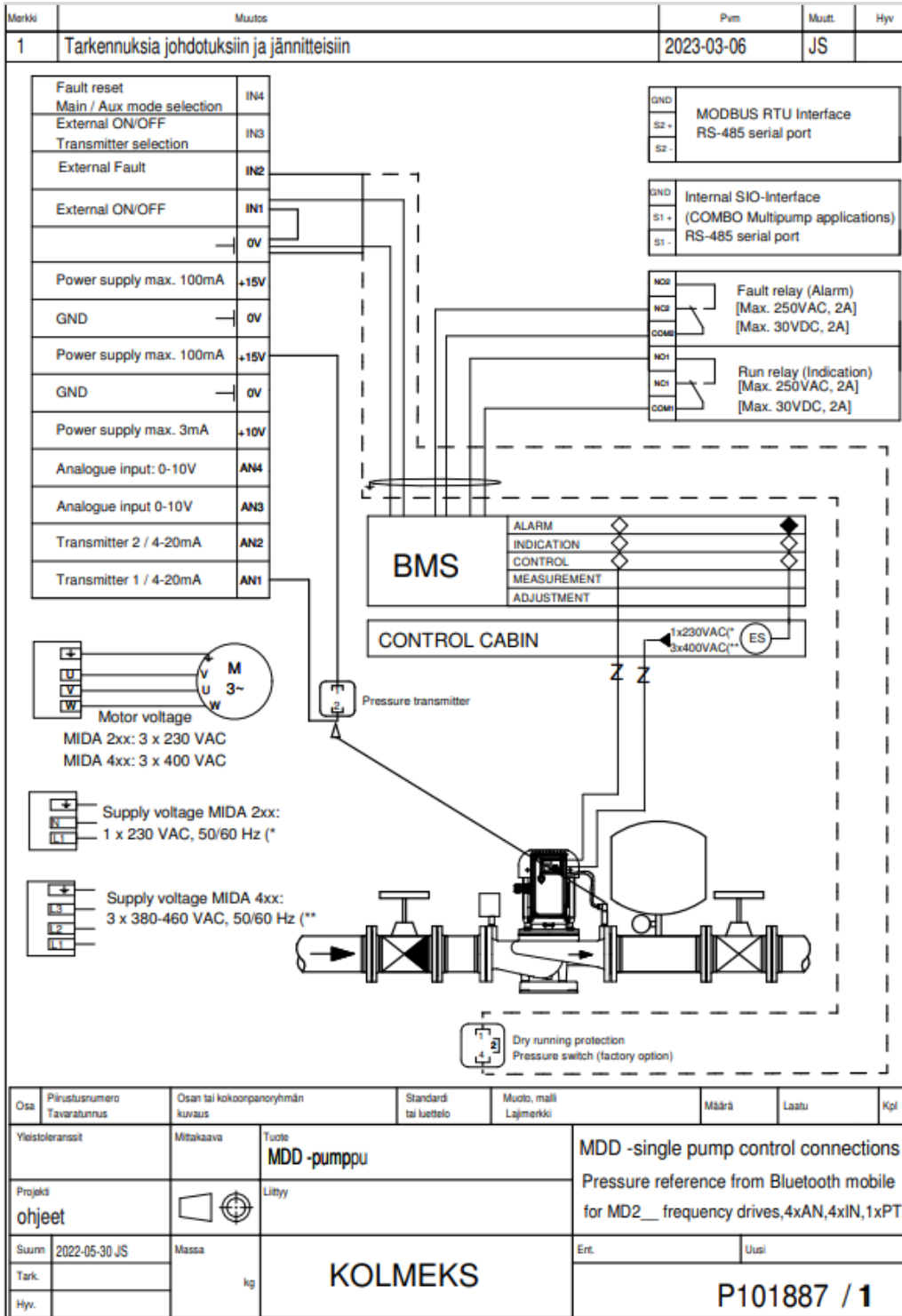



8.4.2 Wiring diagram MDD-single pump, 2 x Din

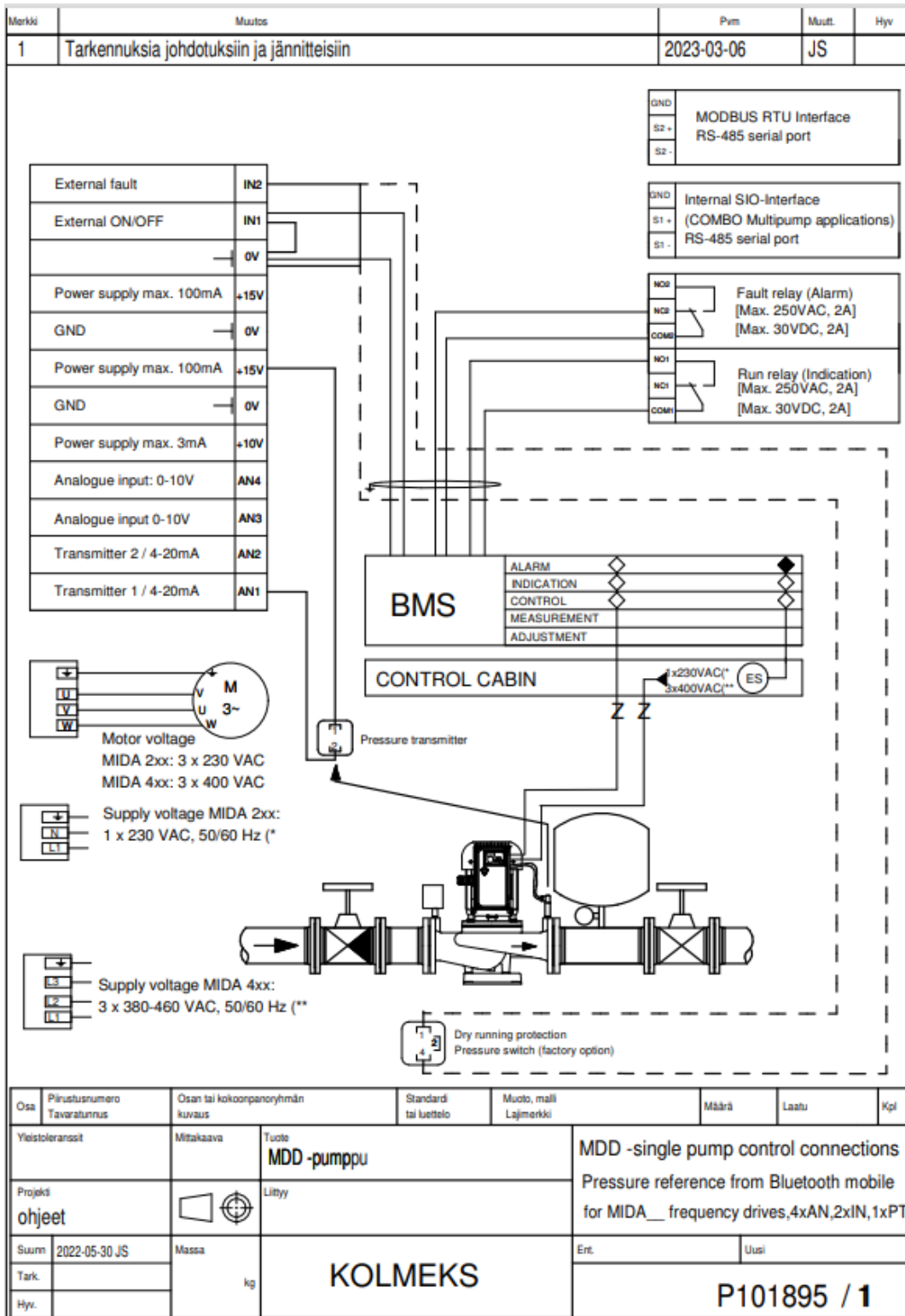

### 8.5 Wiring diagram MDF-single pump

#### 8.5.1 Wiring diagram MDF-single pump, 4 x Din

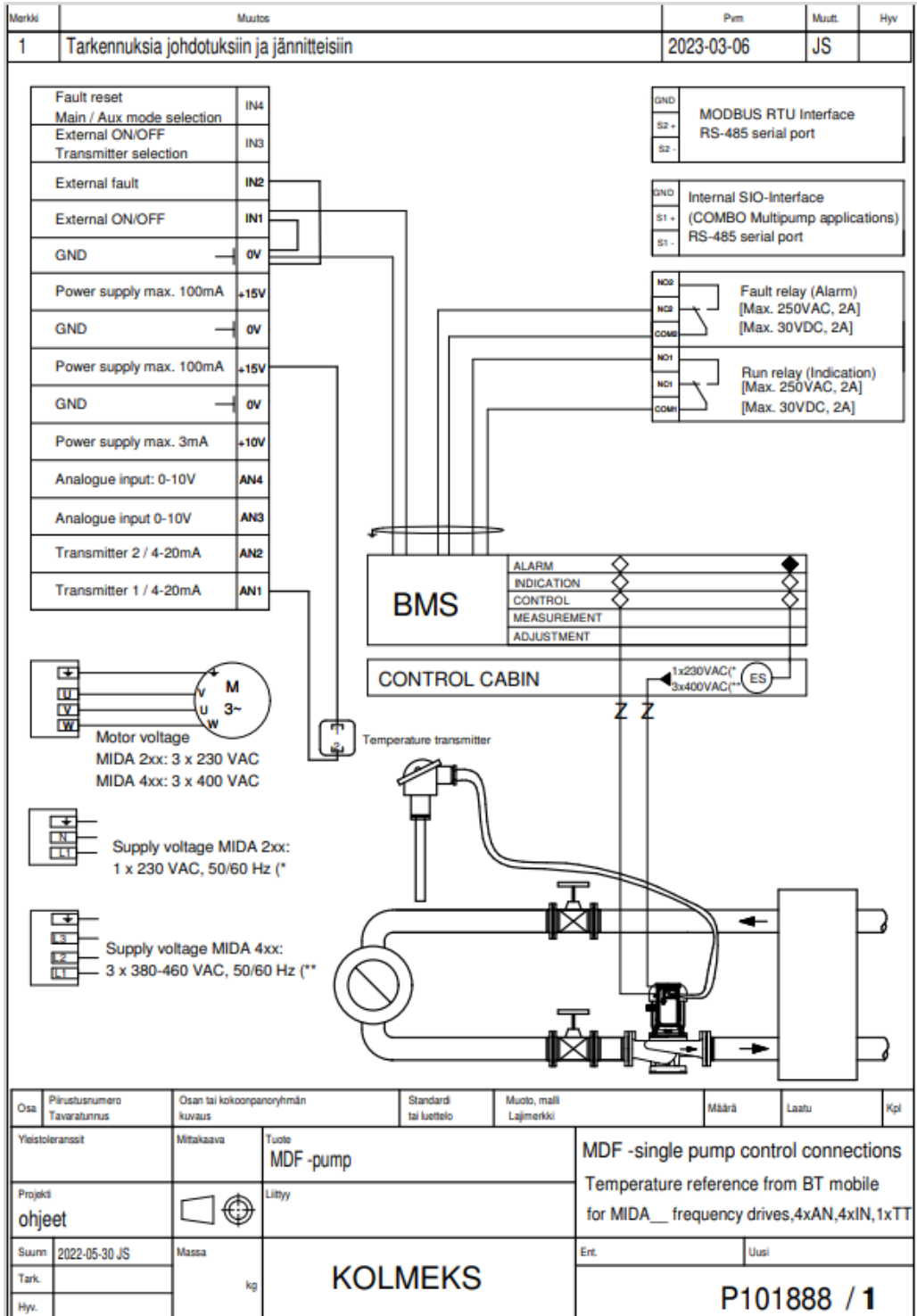

8.5.2 Wiring diagram MDF-single pump, 2 x Din

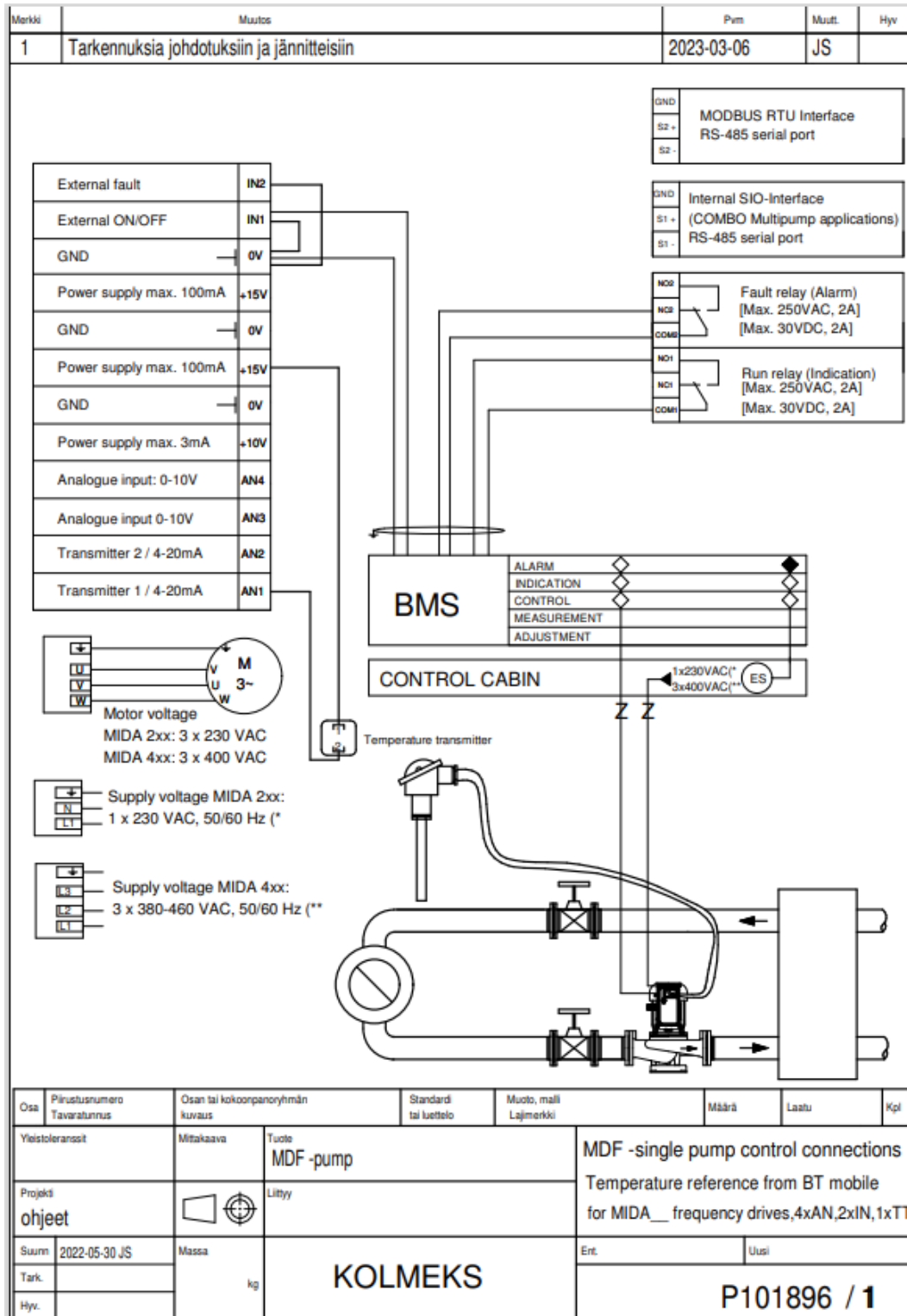

## 8.6 Wiring diagram MDG-single pump

### 8.6.1 Wiring diagram MDG-single pump, 4 x Din

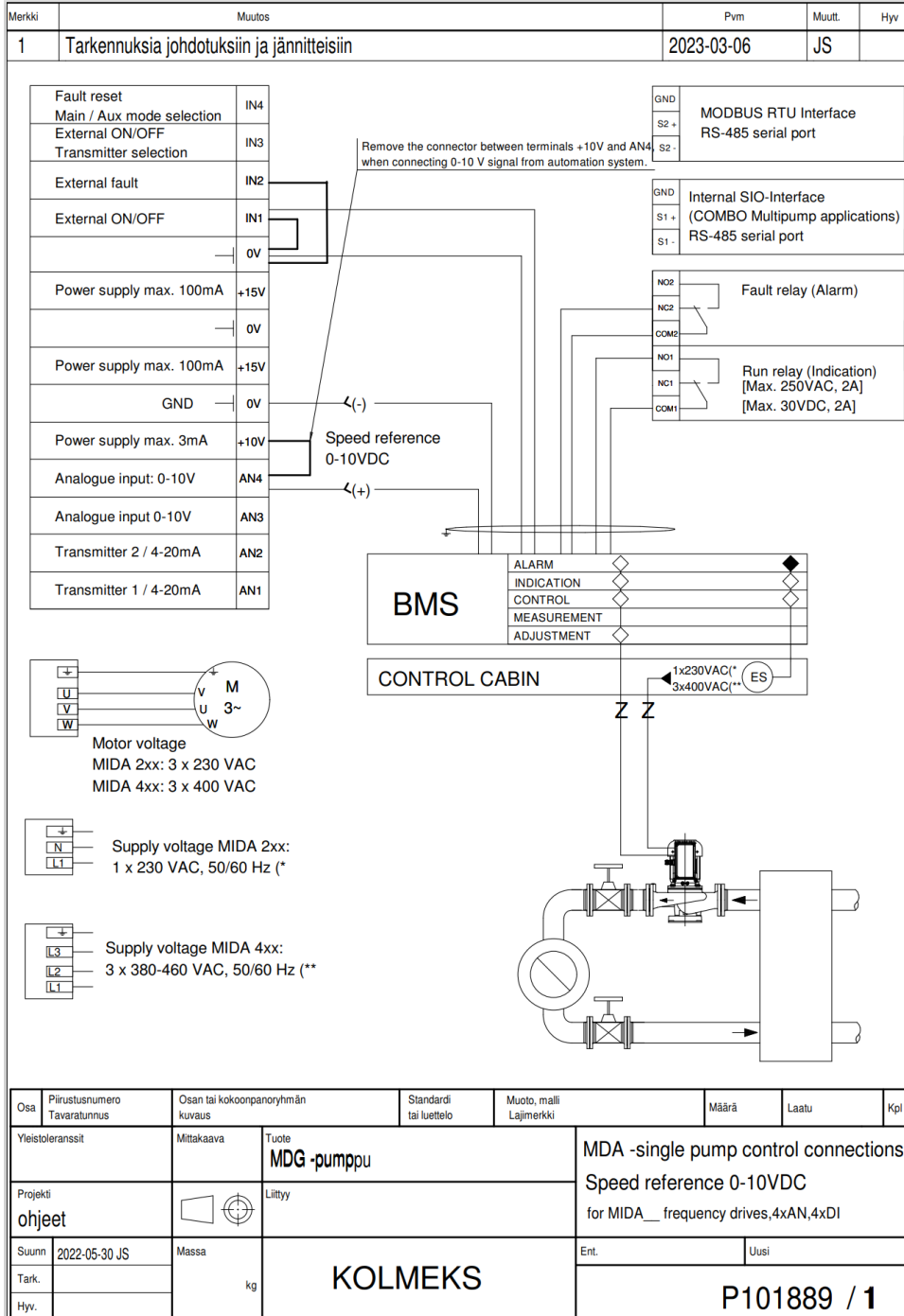

### 8.6.2 Wiring diagram MDG-single pump, 2 x Din

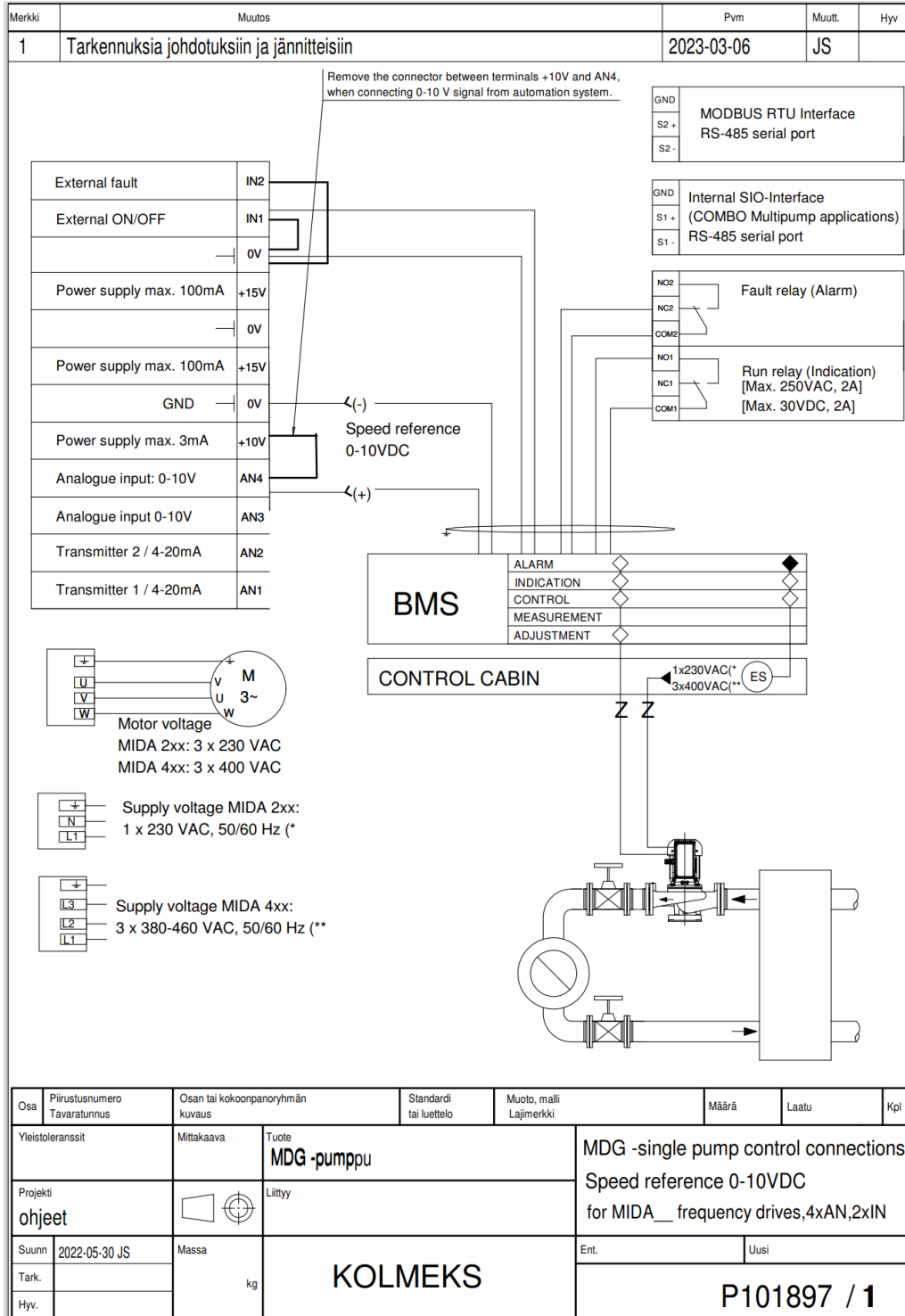

## 8.7 Wiring diagram MDM-single pump

### 8.7.1 Wiring diagram MDM-single pump, 4 x Din

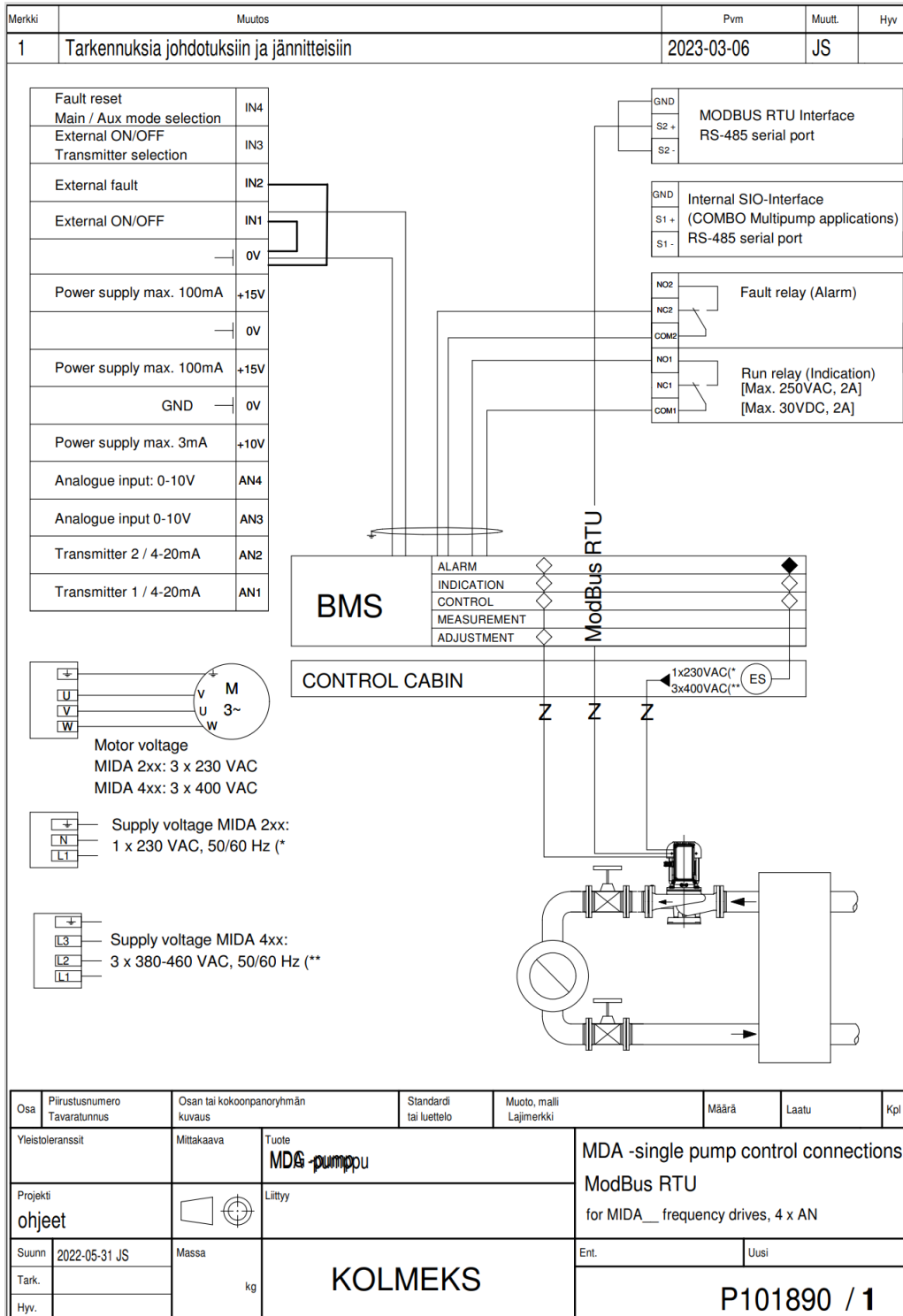

8.7.1 Wiring diagram MDm-single pump, 2 x Din

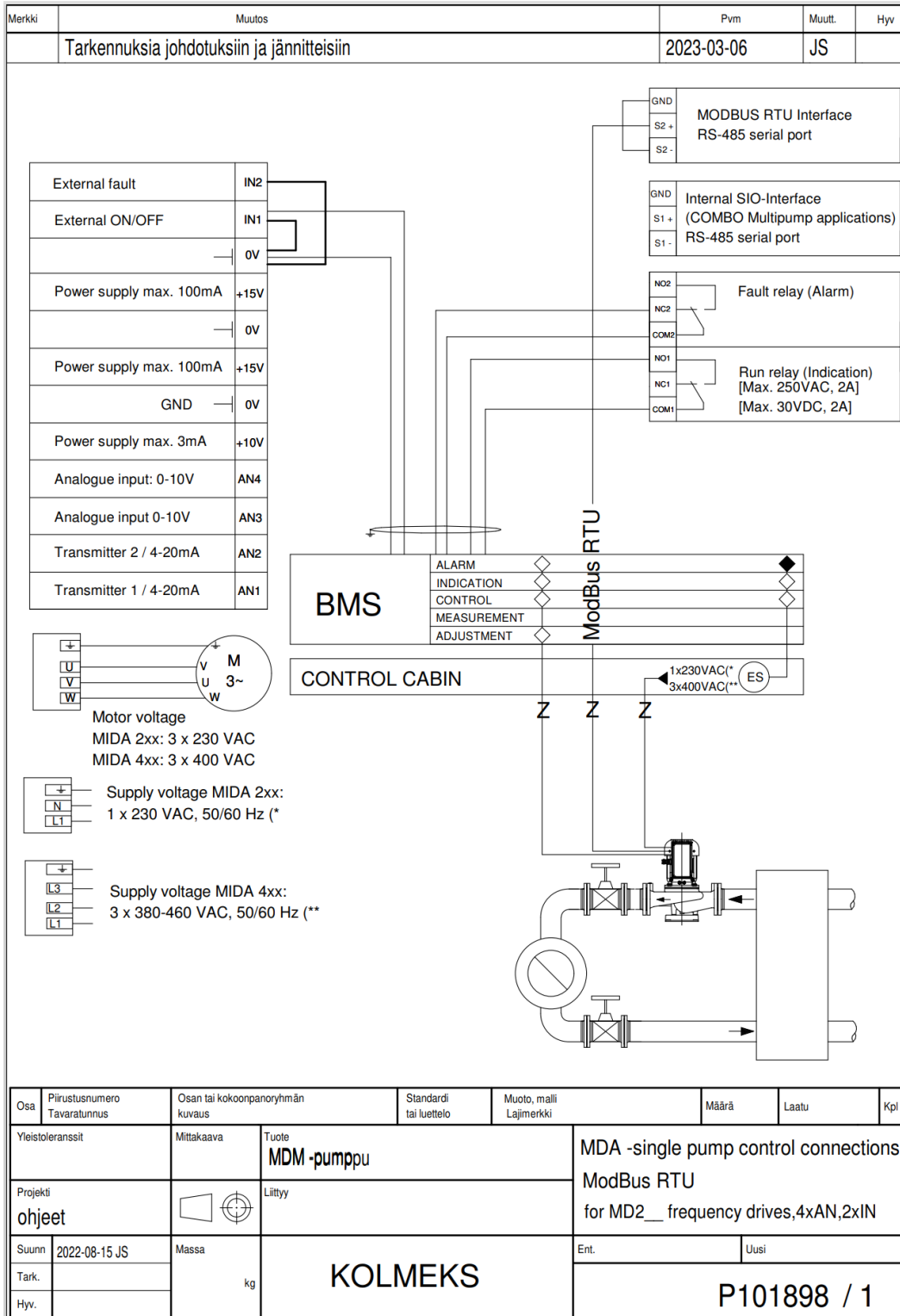

Osa	Piirustusnumero Tavaratunnus	Osan tai kokoonpanoryhmän kuvaus	Standardi tai luettelo	Muoto, malli Lajimerkki	Määrä	Laatu	Kpl
Yleistoleranssit		Mittakaava		Tuote <b>MDM -pumppu</b>	MDA -single pump control connections ModBus RTU for MD2__ frequency drives,4xAN,2xIN		
Projekti <b>ohjeet</b>				Liittyy			
Suunn.	2022-08-15 JS	Massa		<b>KOLMEKS</b>	Ent.	Uusi	
Tark.		kg			<b>P101898 / 1</b>		
Hyv.							

### 8.8 Nastec Now mobile application user guide

Kolmek's MD-pumps can be controlled with Nastec Now mobile application. Application can be downloaded from AppStore and from Google Play store free of charge by using QR-code below or in the first page of this manual. Mobile application is using Bluetooth connection.



Nastec NOW / AppStore



Nastec NOW / Google play

After downloading the application, it is recommended to register application user to ensure complete functionality of the application. Without registering user can execute basic operations, like monitoring and parametrizing.

#### 8.8.1 Registering to Nastec Now user

After starting Nastec Now application, user is requested either to log in or. If you have registered or don't want to register, you can skip this chapter and move 8.8.2. If you haven't registered, choose 'REGISTER', feed your personal information and press again 'REGISTER'. After this you will receive confirmation email. Please, check also your spam folder in case you don't receive email. Log in with used ID you just registered to see basic view of the application.

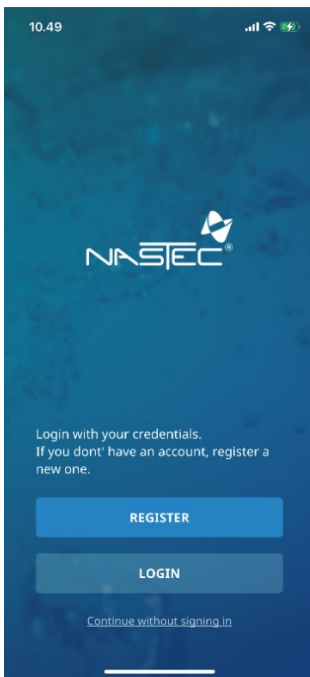

Start view

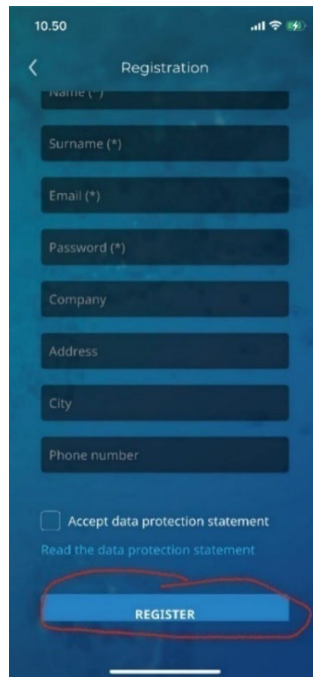

Register view

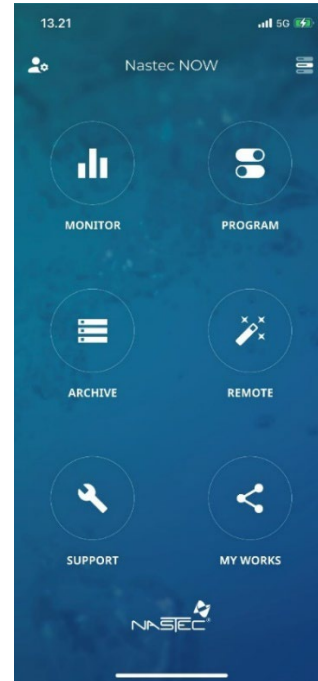

Application basic view



### 8.8.2 Connecting to device and changing the set value

When registering is completer or user doesn't want to register, the use of application can be started. Application opens to basic view, where should be selected `PROGRAM` by pressing the icon. When Nastec Now is not connected to any frequency converter, it opens search view, when user should press `SEARCH`. Application starts searching frequency converters close to user. Please note, that Bluetooth signal flows only some meters. Observed devices are indicated in device list with white color and connection strength is indicated next to the device ID. Press the device ID you want to connect. Finally, the application is asking passwords, which are PW1=001 and PW2=002. After confirming the passwords application moves to program menu.

When the application is connected, in green background states `Connected`.

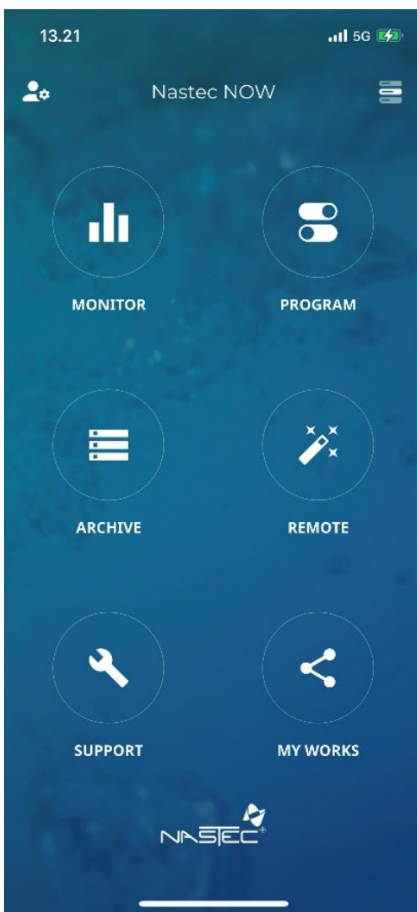

Application basic view

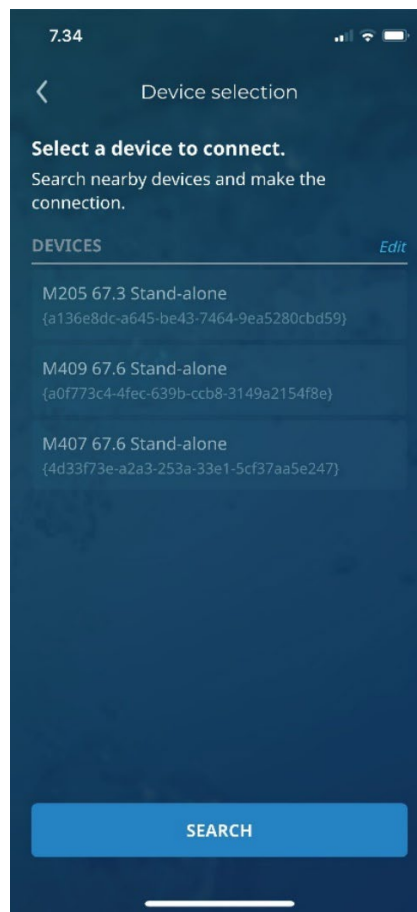

Search view

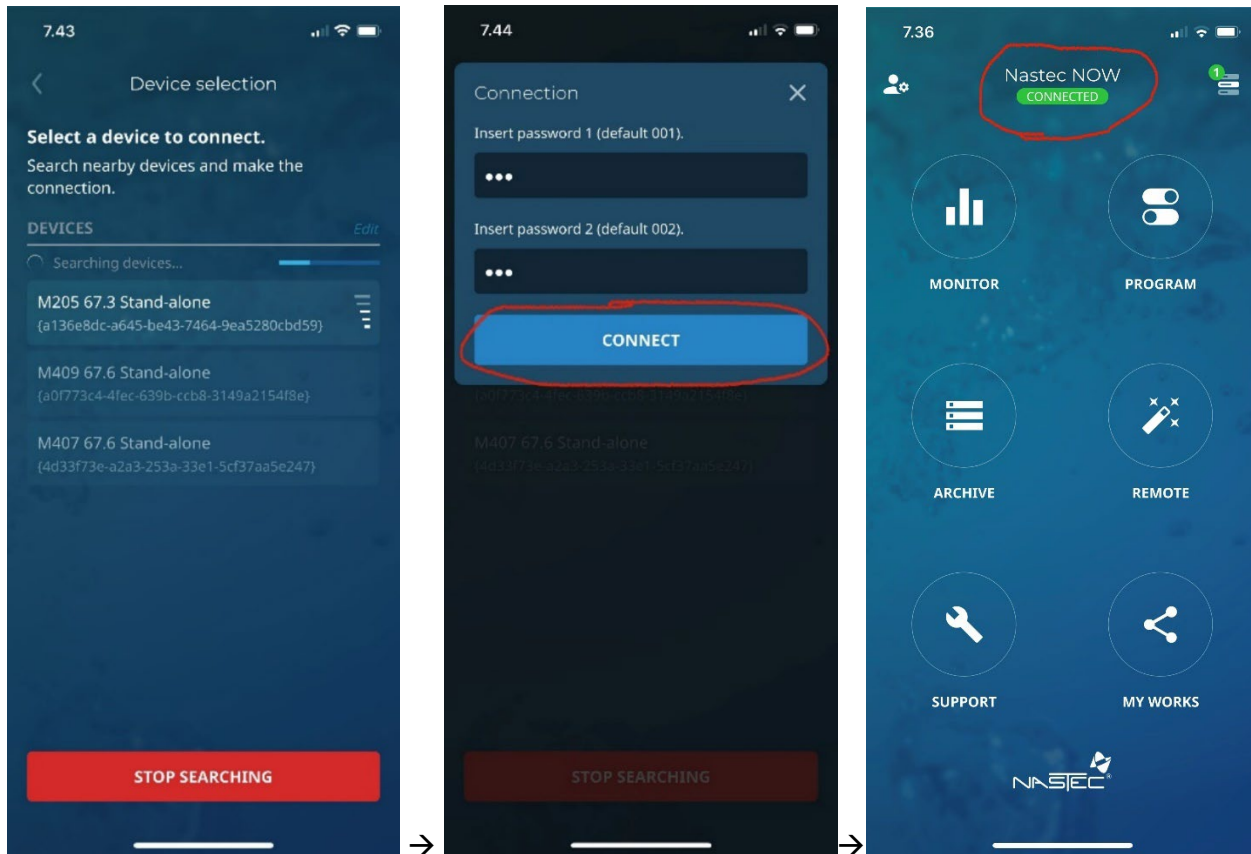

Application has found the drive

Connecting the devices

Application connected to the drive

### 8.8.3 Changing the set value

Set values are changed from NASTEC NOW application `PROGRAM`-menu `CONTROL`-tab. Depending on the operation mode of the pump `CONTROL`-tab looks slightly different. In case of direct frequency reference (MDA-version), should be chosen `Operating frequency [Hz]` by pressing the correct row. After this the application requests to write new frequency reference, which is confirmed by pressing `OK`. Changed value is indicated with yellow color, which means, that value is not written to the frequency converter so far. Changed values are saved to the frequency converter by pressing `WRITE`. Please note, that when writing values with mobile application, pump must be stopped. If the pump is running, application requests to stop the pump before writing the parameters. After writing the latest parameters, pump should be started from `MONITOR`-menu by pressing `START`.

If user wants to use PI-controller or automation system voltage signal instead of fixed speed, should operation mode be changed from `PROGRAM`-menu `CONTROL`-tab by choosing `Control mode`. If PI-controller is used, should be selected `Constant value`. If automation system voltage signal is used, should be selected `External speed`.

Pressure difference (MDB- and MDC-versions) or outlet pressure (MDD-version) set point is changed in corresponding way at `PROGRAM`-menu `CONTROL`-tab. Then should be changed parameter `Set value [m]`. New set value is written in similar way as in case of MDA-version fixed speed reference.

Fixed speed and PI-controller reference value is possible to change without stopping the pump. Please read 5.4 Control methods and choose the correct method for your pump.

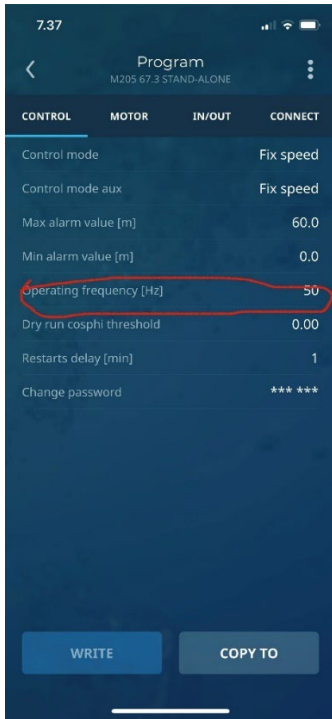

*Program-menu*

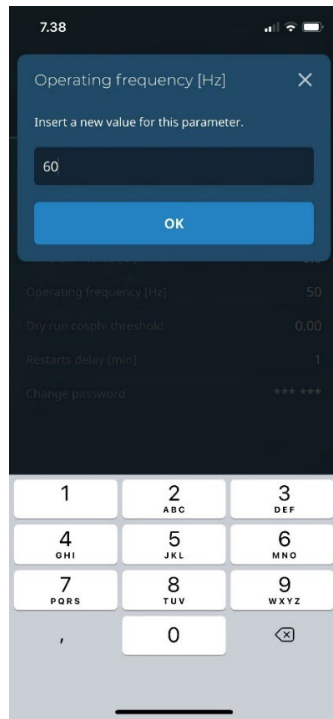

*Placing new frequency reference*

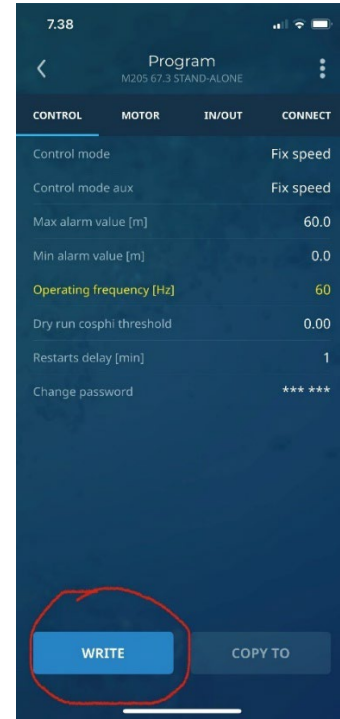

*Saving the changed value*

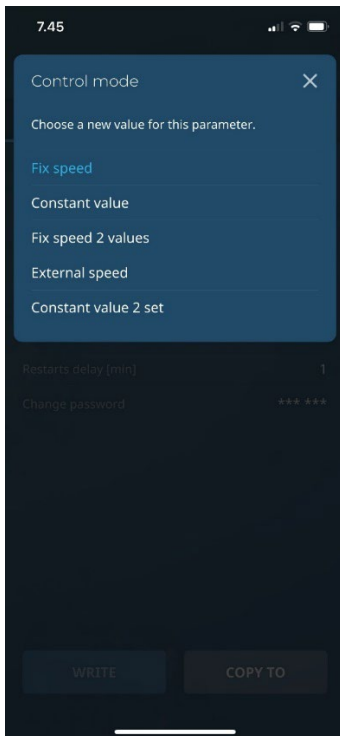

*Changing the operation mode*



*Changing PI-controller set value*

### 8.8.4 Pump and motor monitoring

Pump and motor conditions and active alarms can be monitored with mobile application. When pump is stopped from keypad or from application, in STATUS`-row is indicated `NORMAL OFF`. When pump is running, `STATUS` is `RUN`.

If automation system ON-command (IN1) is disconnected, in `STATUS`-row states `DIGITAL INPUT ACTIVE`. In addition, Monitor menu bottom is shown active warning `W01`.

When pressure transmitter(s) are connected to the pump, measured value is shown in `Actual value [m]` and set point in `Set value [m]`. If set point is indicated with three lines, operation mode doesn't notify measured value, but is operating according to other reference.

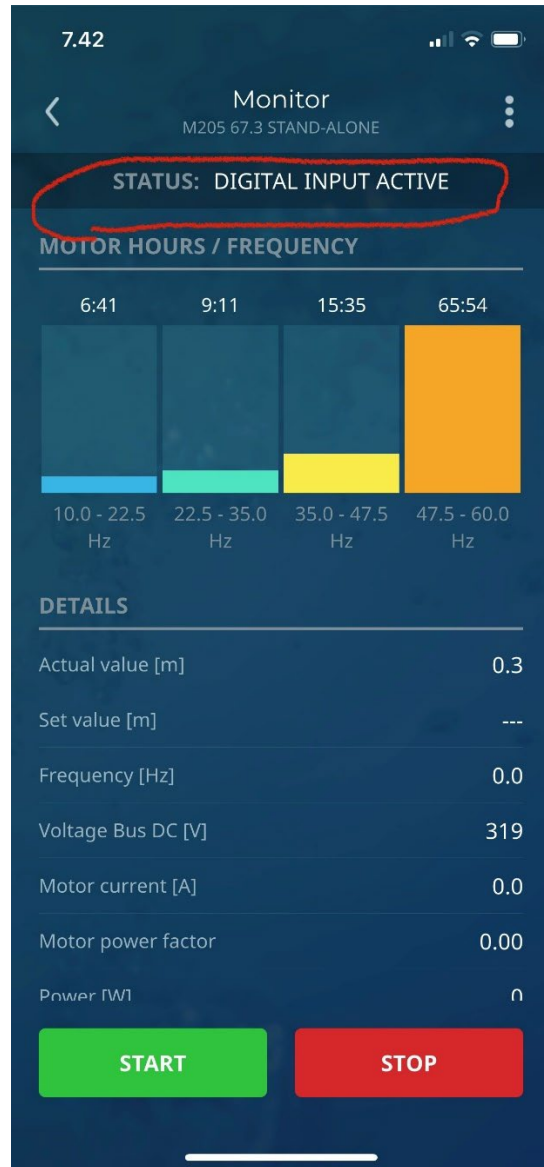
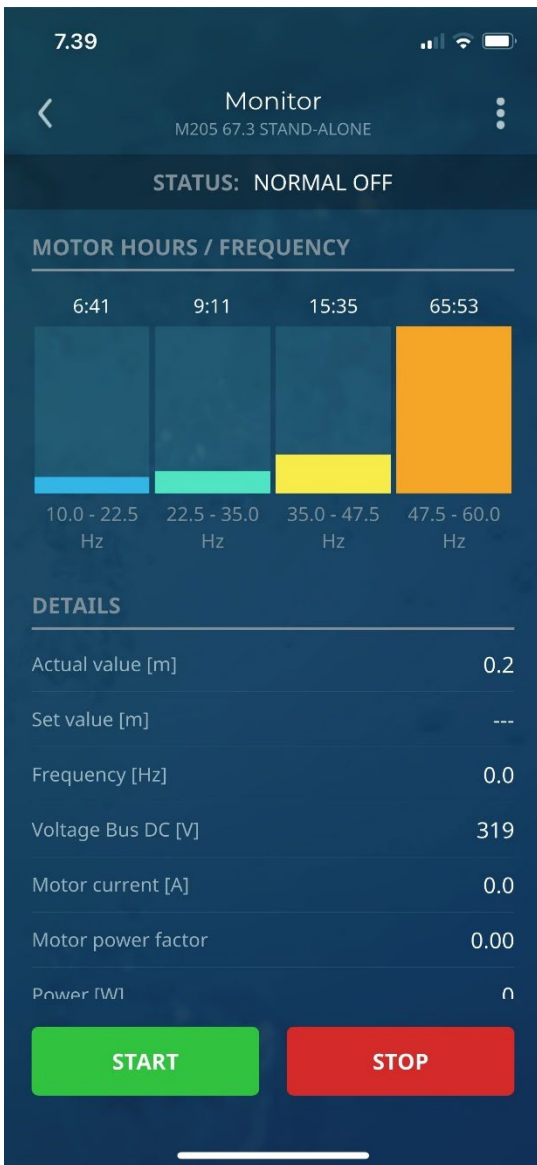

### 8.8.5 Remote use

MD-series pumps can be supervised and controlled with remote connection. To enable remote connection local user needs to be connected to the frequency converter with Bluetooth application. Local user should head to `REMOTE`-menu and choose either `Smart bridge` (remote user with mobile device) or `REMO` (remote user with PC).

When connecting with Smart bridge remote user need 9-digit ID to open the connection. This ID is device specific and should not be shared publicly. As local user tells the ID for remote user either in phone or with message after you have formed connection to the controlled device. Remote user writes your ID to his/her device and requests to open remote connection. Local user needs to approve remote connection. Remote connection requires internet connection from local user.

With Remo press `START REMO`, choose connected device, connect mobile application to controlled device and tell remote user the device name (e.g. M205 67.3). Approve REMO, when remote user requests so.

**NOTE!** Local user needs to be connected and in proximity of controlled device during the remote control.

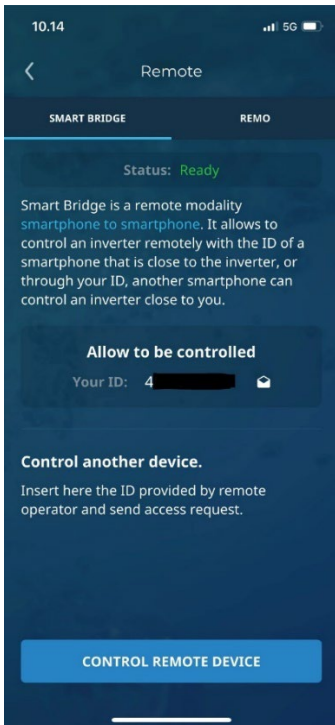

Smart bridge start view

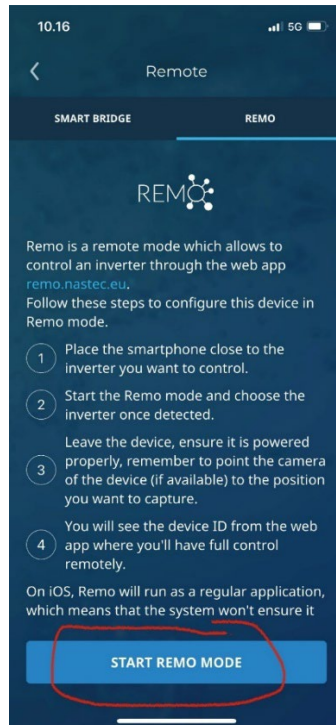

REMO start view